

05-15A MANUAL TRANSAXLE [F25M-R]

MANUAL TRANSAXLE [F25M-R]
 LOCATION INDEX 05-15A-1
 TRANSAXLE OIL
 INSPECTION [F25M-R]..... 05-15A-2
 TRANSAXLE OIL
 REPLACEMENT [F25M-R] 05-15A-2
 OIL SEAL (DIFFERENTIAL) REPLACEMENT
 [F25M-R] 05-15A-2
 MANUAL TRANSAXLE (MTX)
 REMOVAL/INSTALLATION [F25M-R]. 05-15A-4

Lower Arm Ball Joint Removal Note . . . 05-15A-5
 No.4 Engine Mount Bracket
 Removal Note 05-15A-5
 Manual Transaxle (MTX)
 Removal Note 05-15A-5
 Manual Transaxle (MTX)
 Installation Note 05-15A-6
 Engine Mount Member
 Installation Note 05-15A-6

MANUAL TRANSAXLE [F25M-R] LOCATION INDEX

A3U051501025W01

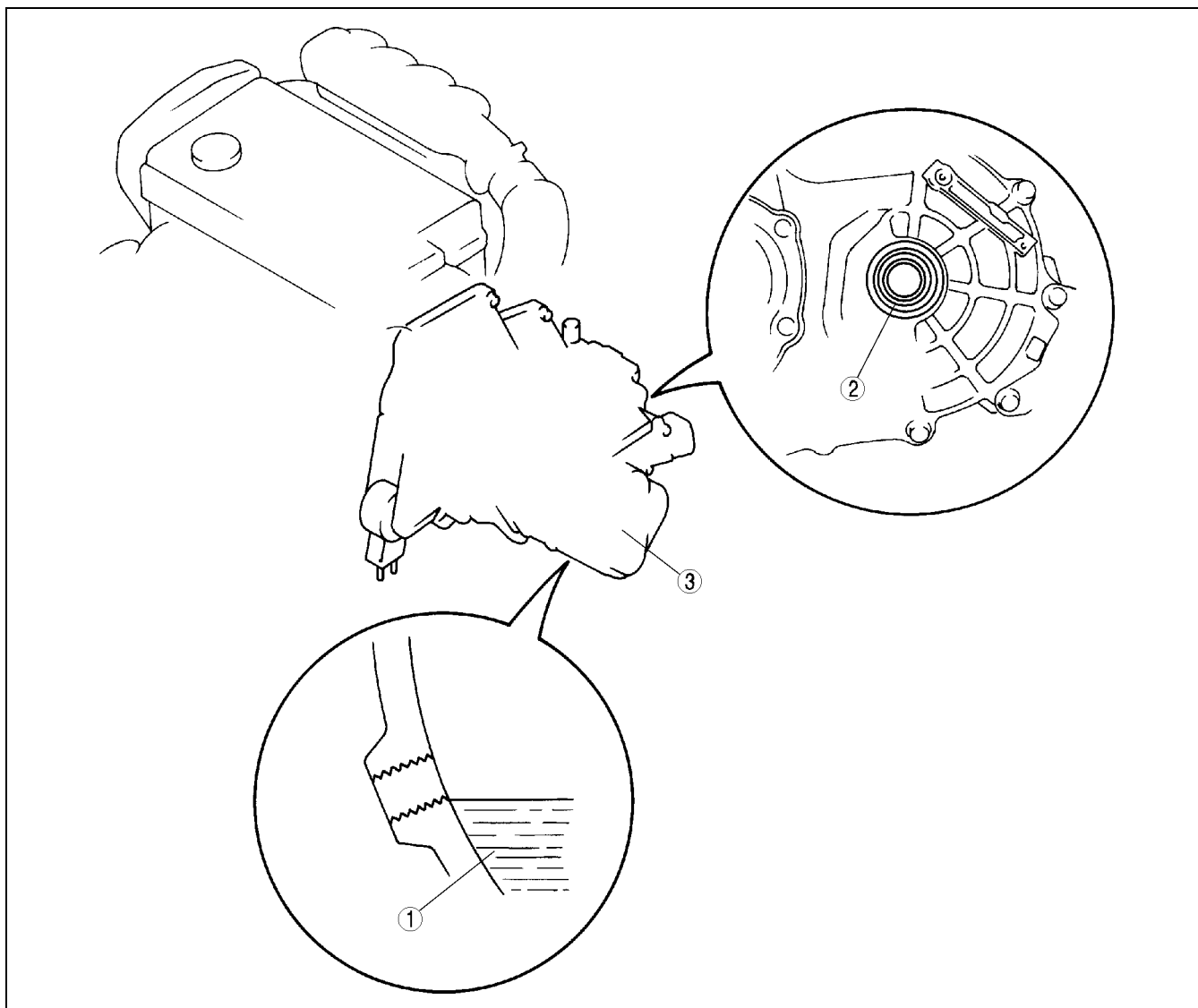

05-15A

1	Transaxle oil (See 05-15A-2 TRANSAXLE OIL INSPECTION [F25M-R]) (See 05-15A-2 TRANSAXLE OIL REPLACEMENT [F25M-R])
---	--

2	Oil seal (differential) (See 05-15A-2 OIL SEAL (DIFFERENTIAL) REPLACEMENT [F25M-R])
3	Manual transaxle (See 05-15A-4 MANUAL TRANSAXLE (MTX) REMOVAL/INSTALLATION [F25M-R])

Z3U515W01

MANUAL TRANSAXLE [F25M-R]

TRANSAXLE OIL INSPECTION [F25M-R]

A3U051527001W01

Note

- Park the vehicle on level ground.

1. Remove the oil level plug and the washer.
2. Verify that the oil is near the bottom of the plug port within the range shown in the figure.
 - If the oil level is low, add the specified type of oil to the bottom of the plug port through the oil level plug hole.

Specified oil

Grade: API service GL-4 or GL-5

Viscosity: SAE 75W—90 (All season) or SAE

80W—90 (Above 10 °C {50 °F})

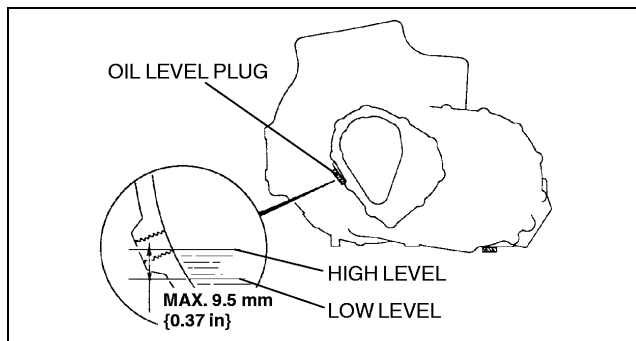

X3U515WA0

3. Install a new washer and the oil level plug.

Tightening torque

40—58 N·m {4.0—6.0 kgf·m, 29—43 ft·lbf}

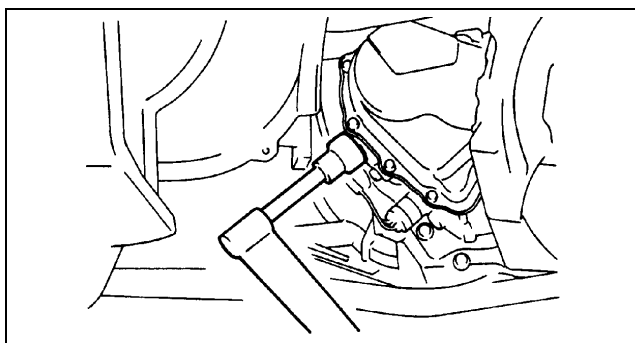

U3U51502

TRANSAXLE OIL REPLACEMENT [F25M-R]

A3U051527001W02

1. Remove the drain plug and the washer.
2. Drain the oil into a container.
3. Install a new washer and the drain plug.

Tightening torque

40—58 N·m {4.0—6.0 kgf·m, 29—43 ft·lbf}

4. Remove the oil level plug and the washer. Add the specified amount and type of oil through the oil level plug hole until the level reaches the bottom of the oil level plug hole.

Specified oil

Grade: API service GL-4 or GL-5

Viscosity: SAE 75W—90 (All season) or SAE

80W—90 (Above 10 °C {50 °F})

Capacity (approximate quantity)

2.68 L {2.83 US qt, 2.36 Imp qt}

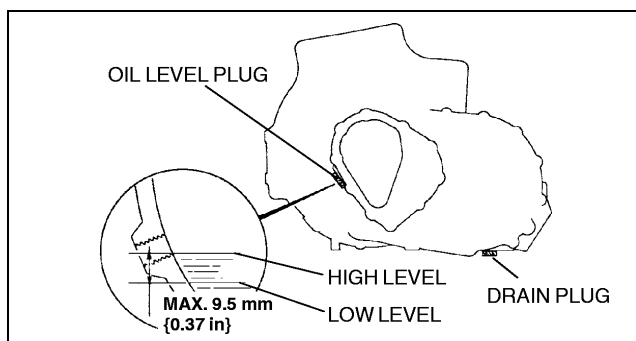

X3U515WA1

5. Install a new washer and the oil level plug.

Tightening torque

40—58 N·m {4.0—6.0 kgf·m, 29—43 ft·lbf}

OIL SEAL (DIFFERENTIAL) REPLACEMENT [F25M-R]

A3U051527165W01

1. Drain the transaxle oil into a container.
2. Separate the drive shaft and joint shaft from the transaxle. (See 03—13—3 JOINT SHAFT REMOVAL/INSTALLATION.) (See 03—13—9 DRIVE SHAFT REMOVAL/INSTALLATION.)
3. Remove the oil seal using a screwdriver and seal remover.

MANUAL TRANSAXLE [F25M-R]

4. Using the **SST** and a hammer, tap the new oil seal in evenly until the **SST** contacts the transaxle case.
5. Coat the oil seal lip with transaxle oil.
6. Insert the drive shaft and joint shaft to the transaxle. (See 03-13-3 JOINT SHAFT REMOVAL/INSTALLATION.) (See 03-13-9 DRIVE SHAFT REMOVAL/INSTALLATION.)
7. Add the specified amount and type of transaxle oil. (See 05-15A-2 TRANSAXLE OIL REPLACEMENT [F25M-R].)

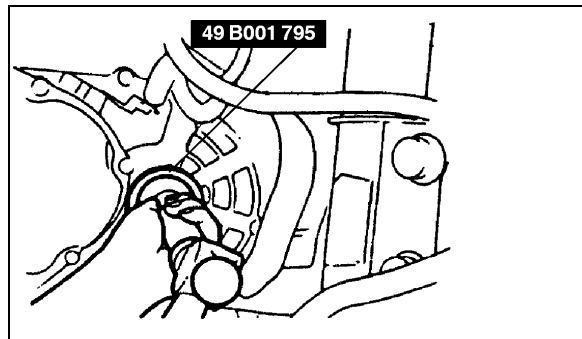

U3U51503

05-15A

MANUAL TRANSAXLE [F25M-R]

A3U051501029W01

MANUAL TRANSAXLE (MTX) REMOVAL/INSTALLATION [F25M-R]

1. Remove the battery, battery cover, and battery tray.
2. Remove the fresh-air duct and air cleaner component.
3. Remove the wheels and tires and splash shields.
4. Remove the EGR pipe, front pipe and TWC. (See 01-15-1 EXHAUST SYSTEM REMOVAL/INSTALLATION.)
5. Drain the transaxle oil into a container.
6. Remove the starter. (See 01-19-1 STARTER REMOVAL/INSTALLATION.)
7. Remove in the order indicated in the table.
8. Install in the reverse order of removal.
9. Add the specified amount of the specified transaxle oil. (See 05-15A-2 TRANSAXLE OIL REPLACEMENT [F25M-R].)
10. Warm up the engine and transaxle, inspect for oil leakage, and inspect the transaxle operation.

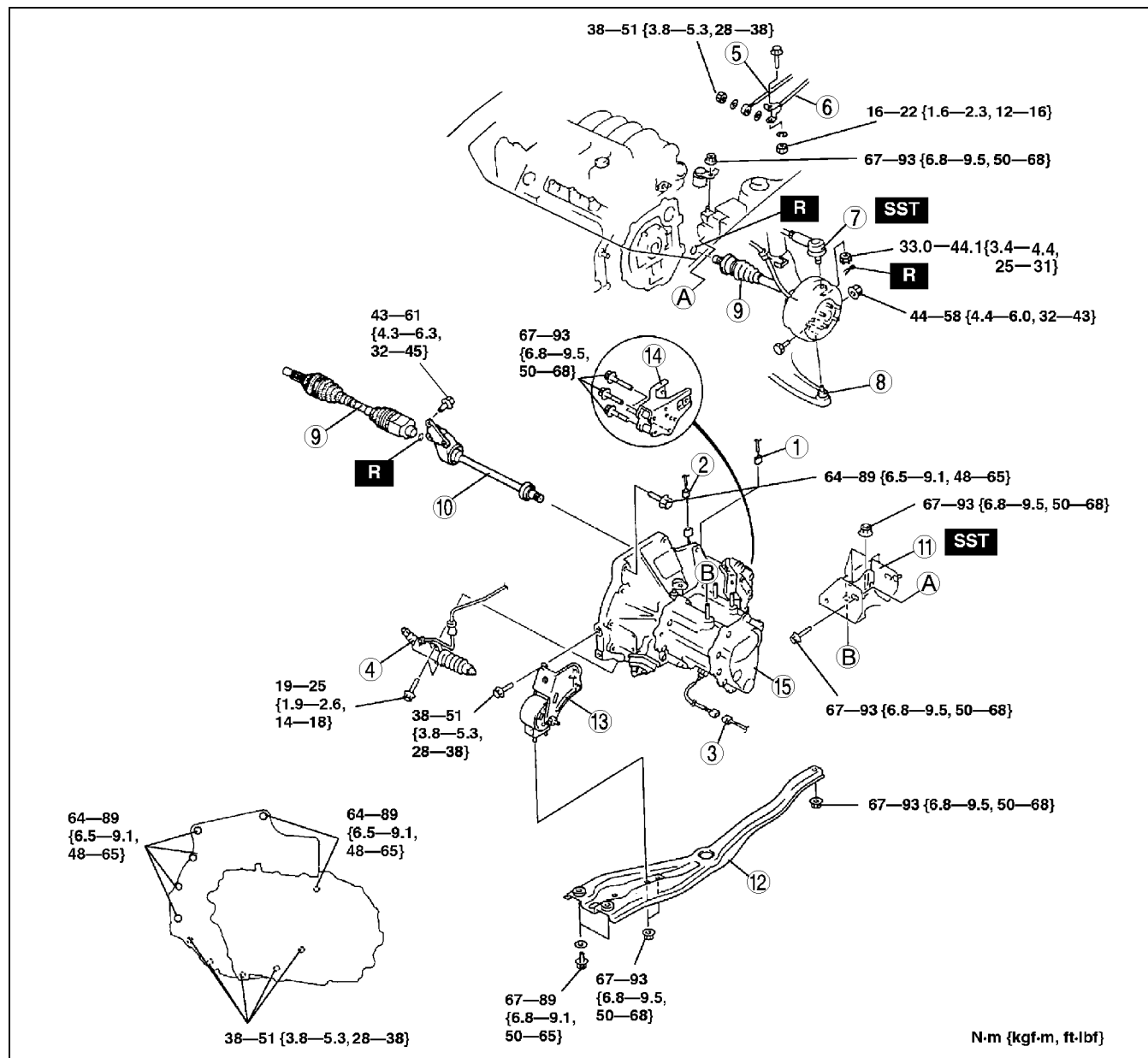

A3U0515W005

1	Speedometer sensor connector
2	Neutral switch connector
3	Back-up light switch connector
4	Clutch release cylinder
5	Extension bar
6	Change control rod

7	Tie-rod end ball joint (See 06-12-9 STEERING GEAR AND LINKAGE REMOVAL/INSTALLATION.)
8	Lower arm ball joint (See 05-15A-5 Lower Arm Ball Joint Removal Note.)

MANUAL TRANSAXLE [F25M-R]

9	Drive shaft (See 03-13-9 DRIVE SHAFT REMOVAL/ INSTALLATION.)
10	Joint shaft (See 03-13-3 JOINT SHAFT REMOVAL/ INSTALLATION.)
11	No.4 engine mount bracket (See 05-15A-5 No.4 Engine Mount Bracket Removal Note.)
12	Engine mount member (See 05-15A-6 Engine Mount Member Installation Note.)

13	No.2 engine mount
14	No.1 engine mount bracket
15	MTX (See 05-15A-5 Manual Transaxle (MTX) Removal Note.) (See 05-15A-6 Manual Transaxle (MTX) Installation Note.)

Lower Arm Ball Joint Removal Note

Caution

- Wrap a rag around the ball joint dust seal to protect it from getting damages.

1. Pry the lower arm out of the knuckle.

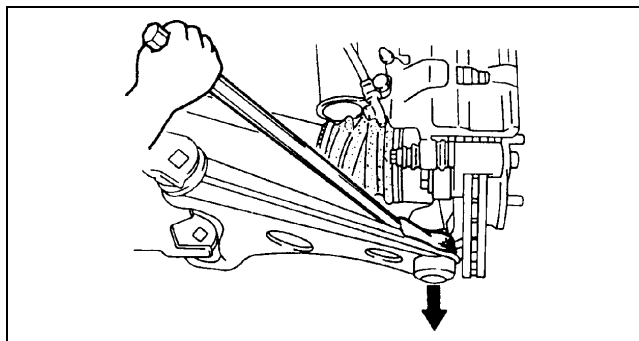

X3U515WA4

05-15A

No.4 Engine Mount Bracket Removal Note

1. Support the engine using the **SST** before removing the No.4 engine mount bracket.
2. Remove the No.4 engine mount bracket.

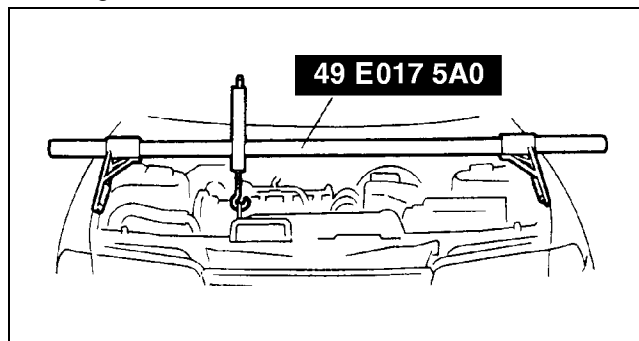

Z3U110WFK

Manual Transaxle (MTX) Removal Note

1. Loosen the **SST** (49 E017 5A0) and lean the engine toward the transaxle.
2. Support the transaxle on a jack.
3. Remove the transaxle mounting bolts.
4. Remove the transaxle.

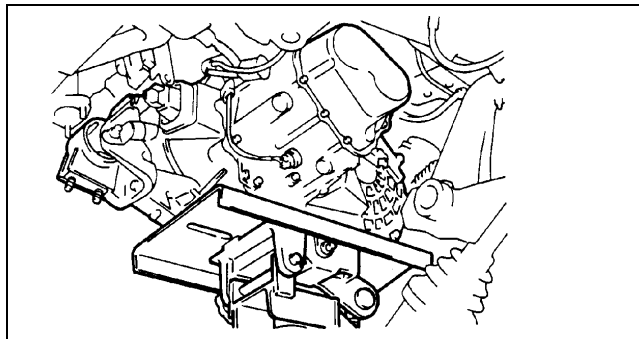

X3U515WA6

MANUAL TRANSAXLE [F25M-R]

Manual Transaxle (MTX) Installation Note

1. Set the transaxle on a jack and lift into place.
2. Install the transaxle mounting bolts.

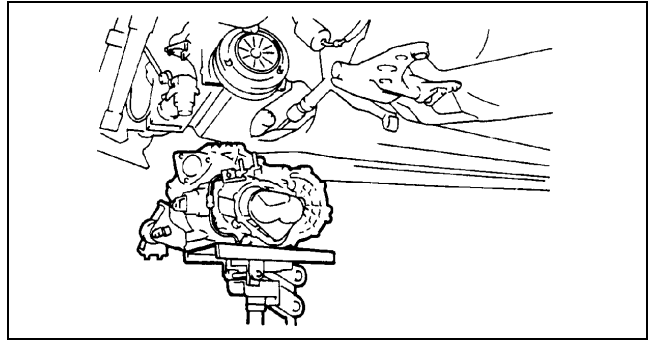

X3U515WA7

Engine Mount Member Installation Note

1. Verify that the engine mount rubbers are installed as shown.

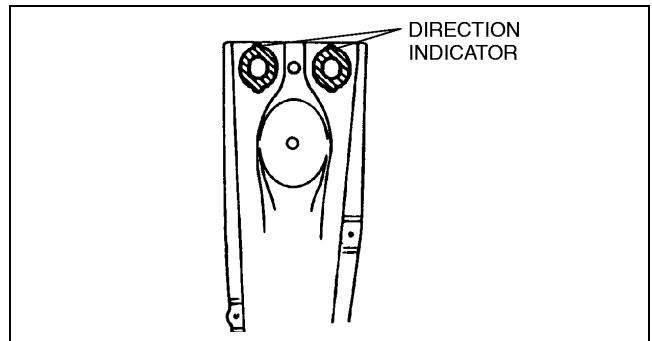

X3U515WA8

2. Put the No.2 engine mount stud bolts in the installation holes when installing the engine mount member.
3. Tighten bolt A and nut B.

Tightening torque

Bolt A: 67—89 N·m {6.8—9.1 kgf·m, 50—65 ft·lbf}

Nut B: 67—93 N·m {6.8—9.5 kgf·m, 50—68 ft·lbf}

4. Tighten nuts C.

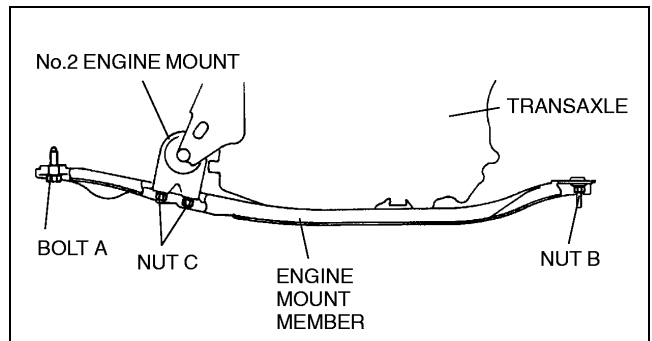

X3U515WA9

Tightening torque

Nut C: 67—93 N·m {6.8—9.5 kgf·m, 50—68 ft·lbf}

5. By aligning the holes with the stud bolts, install the No.4 engine mount bracket to the transaxle.
6. Align the hole of the No.4 engine mount bracket with the No.4 engine mount rubber on vehicle, and temporarily tighten bolt D.
7. Tighten nuts E, then bolt D.

Tightening torque

Bolt D and nut E: 67—93 N·m {6.8—9.5 kgf·m, 50—68 ft·lbf}

8. Remove the SST (49 E017 5A0).

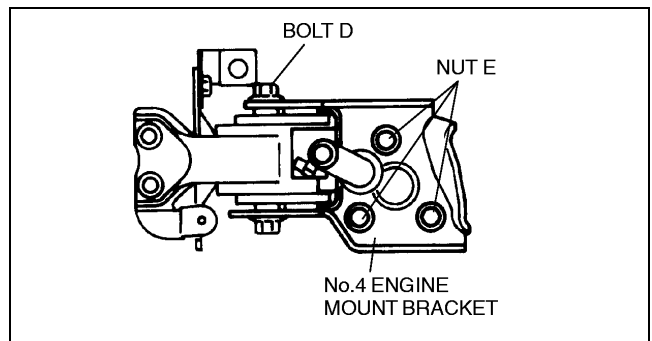

X3U515WB0