

03-13 DRIVE SHAFT

DRIVE SHAFT LOCATION INDEX	03-13-2
JOINT SHAFT PRE-INSPECTION	03-13-2
JOINT SHAFT	
REMOVAL/INSTALLATION	03-13-3
Right Drive Shaft and Axle	
Removal Note	03-13-4
Joint Shaft Removal Note	03-13-4
Clip Installation Note	03-13-5
Joint Shaft Installation Note	03-13-5
Right Drive Shaft and Axle	
Installation Note	03-13-5
JOINT SHAFT	
DISASSEMBLY/ASSEMBLY	03-13-6
Joint Shaft Disassembly Note	03-13-6
Bearing Disassembly Note	03-13-6
Dust Seal (right) Assembly Note	03-13-7
Bearing Assembly Note	03-13-7
Dust Seal (left) Assembly Note	03-13-7
Joint Shaft Assembly Note	03-13-8
DRIVE SHAFT PRE-INSPECTION	03-13-8
DRIVE SHAFT	
REMOVAL/INSTALLATION	03-13-9
Drive Shaft Removal Note	03-13-9
Drive Shaft Installation Note	03-13-11
DRIVE SHAFT	
(ZM, FS ATX, FS MTX RIGHT SIDE)	
DISASSEMBLY/ASSEMBLY	03-13-12
Boot Band (Wheel Side)	
Disassembly Note	03-13-12

Boot Band (Transaxle Side)	
Disassembly Note	03-13-13
Outer Ring Disassembly Note	03-13-13
Tripod Joint Disassembly Note	03-13-13
Boot Disassembly Note	03-13-13
ABS Sensor Rotor (With ABS)	
Disassembly Note	03-13-14
ABS Sensor Rotor (With ABS)	
Assembly Note	03-13-14
Dynamic Damper Assembly Note	03-13-14
Boot Assembly Note	03-13-14
Tripod Joint Assembly Note	03-13-15
Outer Ring Assembly Note	03-13-15
Boot Band (Transaxle Side)	
Assembly Note	03-13-16
Boot Band (Wheel Side)	
Assembly Note	03-13-16
DRIVE SHAFT (FS MTX LEFT SIDE)	
DISASSEMBLY/ASSEMBLY	03-13-17
Outer Ring Disassembly Note	03-13-18
Balls, Inner Ring, Cage	
Disassembly Note	03-13-18
Dynamic Damper Assembly Note	03-13-18
Boot Assembly Note	03-13-18
Cage, Inner Ring, Balls, Snap Ring	
Assembly Note	03-13-19
Outer Ring, Clip Assembly Note	03-13-19

03-13

DRIVE SHAFT

DRIVE SHAFT LOCATION INDEX

A3U031325500W01

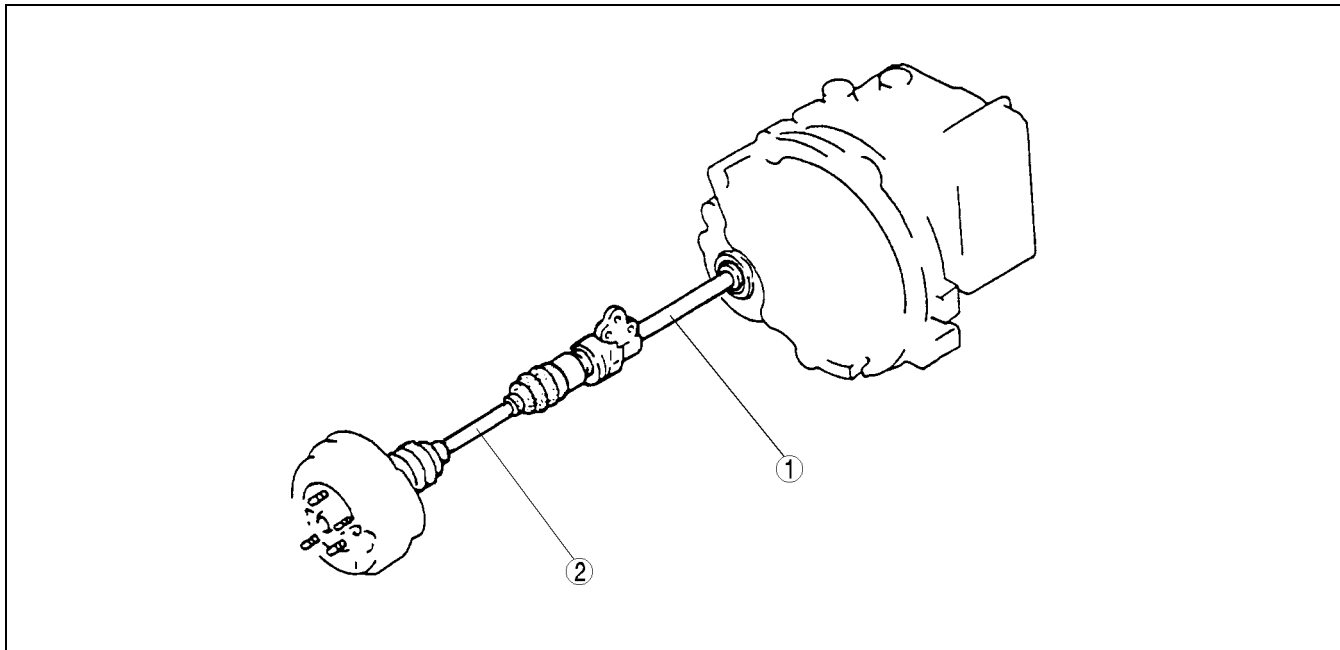

Z3U0313W007

1	Joint shaft (See 03-13-2 JOINT SHAFT PRE-INSPECTION) (See 03-13-3 JOINT SHAFT REMOVAL/ INSTALLATION) (See 03-13-6 JOINT SHAFT DISASSEMBLY/ ASSEMBLY)
---	---

2	Drive shaft (See 03-13-8 DRIVE SHAFT PRE-INSPECTION) (See 03-13-9 DRIVE SHAFT REMOVAL/ INSTALLATION) (See 03-13-12 DRIVE SHAFT (ZM, FS ATX, FS MTX RIGHT SIDE) DISASSEMBLY/ASSEMBLY) (See 03-13-17 DRIVE SHAFT (FS MTX LEFT SIDE) DISASSEMBLY/ASSEMBLY)
---	--

JOINT SHAFT PRE-INSPECTION

A3U031325700W01

1. Verify that the joint shaft is not twisted or cracked.
 - Replace it as necessary.
2. Turn the joint shaft by hand and verify that the bearing rotates smoothly and freely.
 - Replace it as necessary.

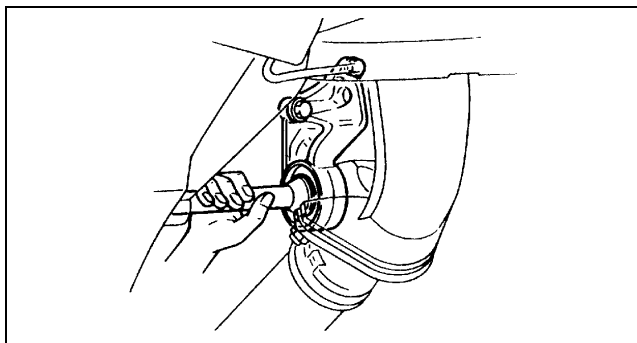

X3U313WA0

DRIVE SHAFT

JOINT SHAFT REMOVAL/INSTALLATION

A3U031325700W02

Caution

- Performing the following procedures without first removing the ABS wheel-speed sensor could cause an open circuit in the harness if it is pulled by mistake. Before performing the following procedures, remove the ABS wheel-speed sensor (axle side) and fix it to an appropriate place where the sensor will not be pulled by mistake while servicing the vehicle.

1. Drain the transaxle oil.
2. Remove in the order indicated in the table.
3. Install in the reverse order of removal.

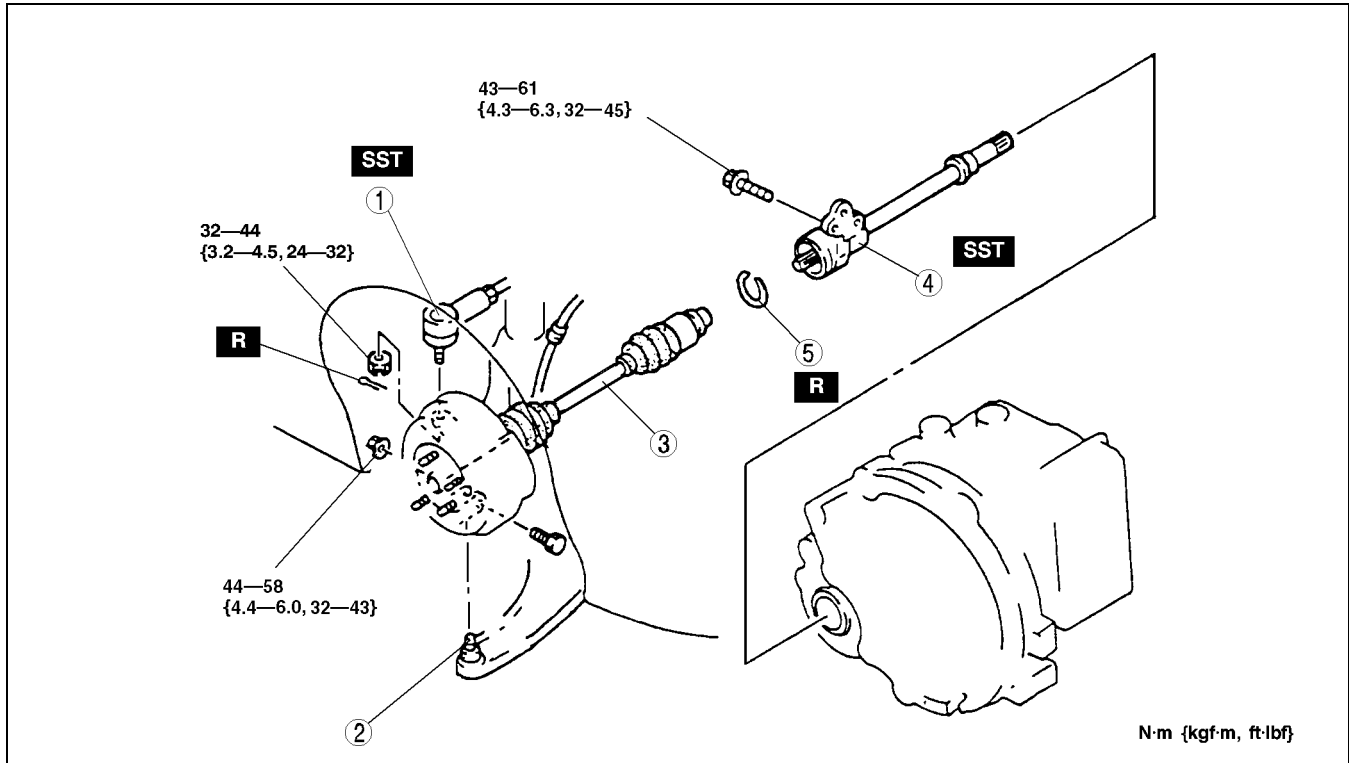

03-13

Y3E6316W001

1	Tie-rod end
2	Lower arm ball joint
3	Right drive shaft and axle (See 03-13-4 Right Drive Shaft and Axle Removal Note) (See 03-13-5 Right Drive Shaft and Axle Installation Note)

4	Joint shaft (See 03-13-4 Joint Shaft Removal Note) (See 03-13-5 Joint Shaft Installation Note)
5	Clip (See 03-13-5 Clip Installation Note)

DRIVE SHAFT

Right Drive Shaft and Axle Removal Note

1. Remove the clinch bolt and nut.
2. Wrap a rag around the ball joint dust boot.
3. Pry the lower arm out of the knuckle.

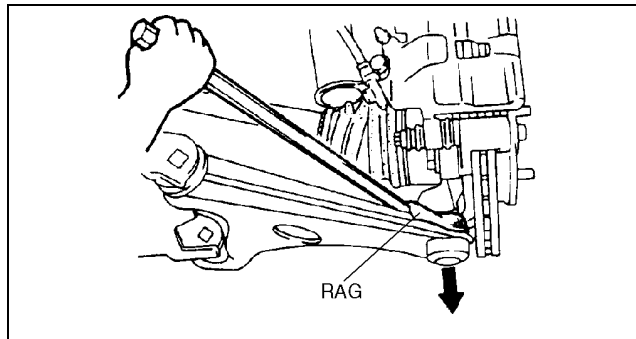

Z3U0312W003

4. As shown in the figure, insert a pry bar between the right drive shaft and the joint shaft and tap on the bar to uncouple them.

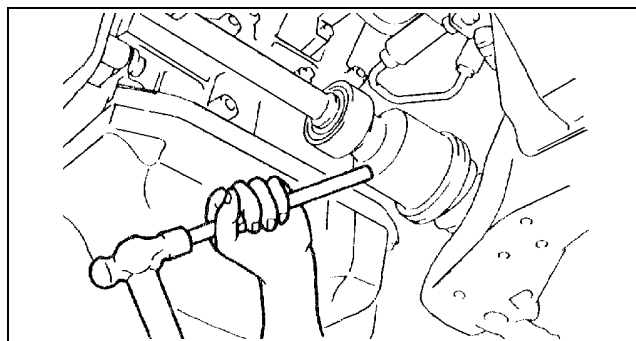

Y3E6316W007

Joint Shaft Removal Note

1. Secure the joint shaft bracket cylinder block.
2. Pull the joint shaft straight out.

Caution

- The sharp edges of the joint shaft can slice or puncture the oil seal. Be careful when installing the joint shaft to the transaxle.

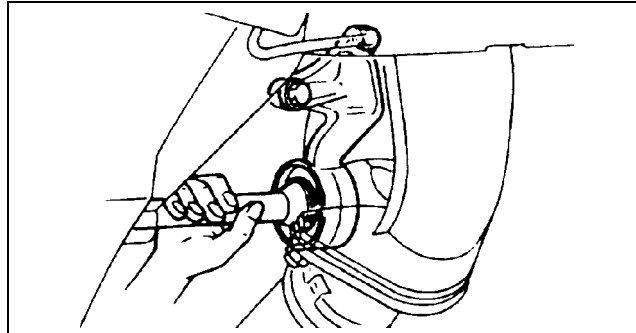

Y3E6316W008

3. Insert the **SST** into the transaxle to hold the side gears after joint shaft removed.

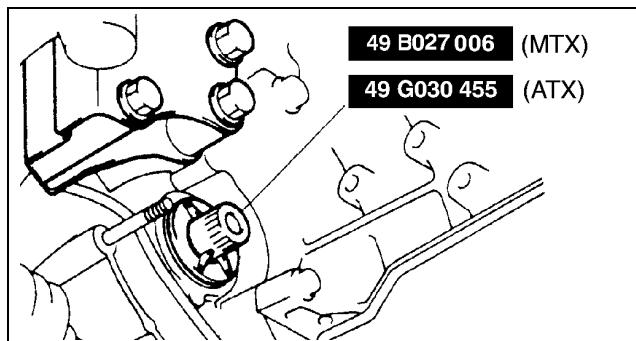

Y3E6316W009

DRIVE SHAFT

Clip Installation Note

1. Install a new clip onto the joint shaft with the opening facing upward. Ensure that the diameter of the clip does not exceed the specification on installation.
2. After installation, measure the outer diameter. If it exceeds the specification, repeat steps 1—2 using a new clip.

Outer diameter specification
30.0 mm {1.18 in}

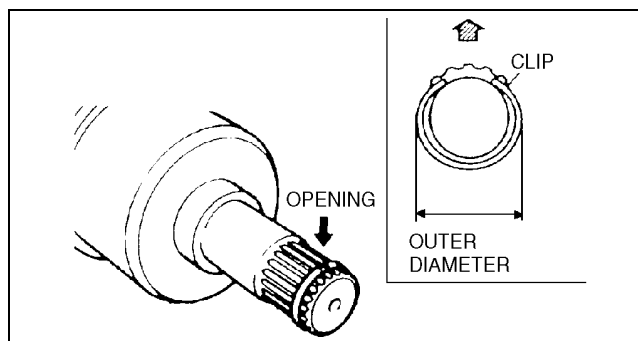

03-13

Joint Shaft Installation Note

1. Install the joint shaft with the end gap of the new clip facing upward.
2. For FS engine, tighten the bolt A, then tighten the bolt B.

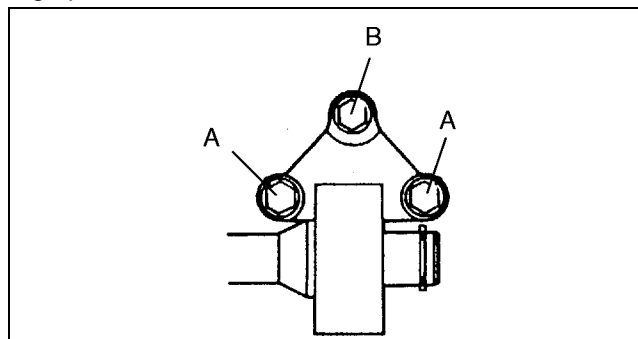

Right Drive Shaft and Axle Installation Note

1. Push the drive shaft into the joint shaft.
2. After installation, pull the transaxle side outer ring forward to verify that the drive shaft is securely held by the clip.
3. Set the lower arm with steering knuckle, then tighten the bolt and nut.

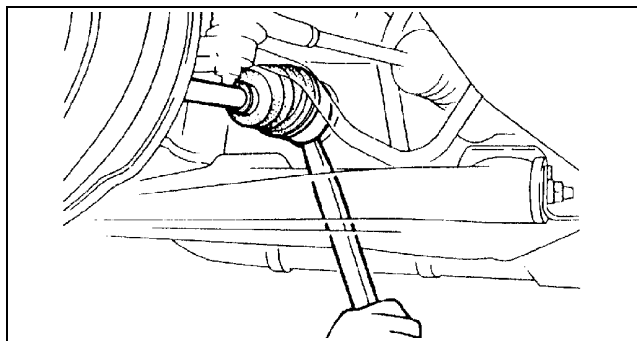

DRIVE SHAFT

JOINT SHAFT DISASSEMBLY/ASSEMBLY

A3U031325700W03

1. Disassemble in the order indicated in the table.
2. Assemble in the reverse order of removal.

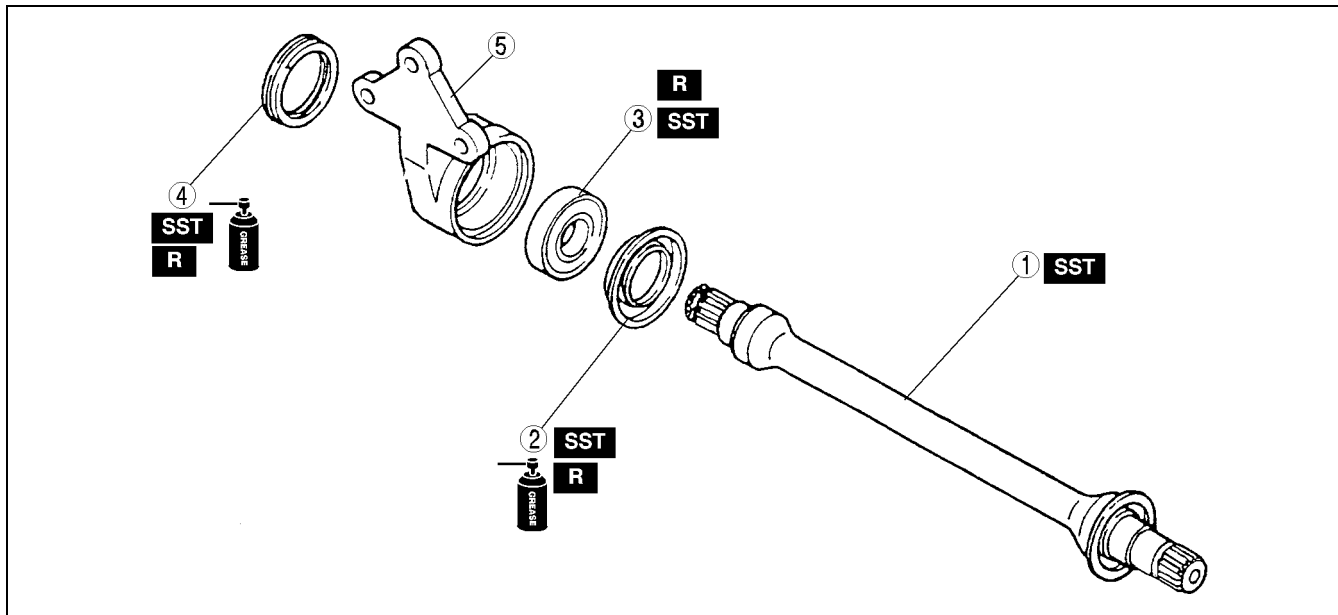

Y3E6316W002

1	Joint shaft (See 03-13-6 Joint Shaft Disassembly Note) (See 03-13-8 Joint Shaft Assembly Note)
2	Dust Seal (left) (See 03-13-7 Dust Seal (left) Assembly Note)

3	Bearing (See 03-13-6 Bearing Disassembly Note) (See 03-13-7 Bearing Assembly Note)
4	Dust Seal (right) (See 03-13-7 Dust Seal (right) Assembly Note)
5	Bracket

Joint Shaft Disassembly Note

1. Disassemble the joint shaft using the SST.

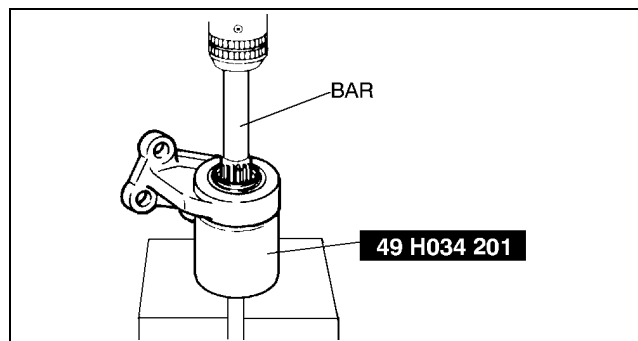

A3U0313W002

Bearing Disassembly Note (If the bearing remains on the bracket)

1. Remove the bearing using the SST.

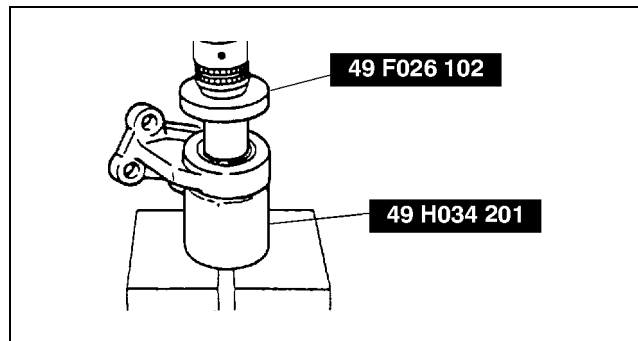

Y3E6316W014

DRIVE SHAFT

(If the bearing remains on the joint shaft)

1. While holding the joint shaft, press out the bearing using the **SST**.

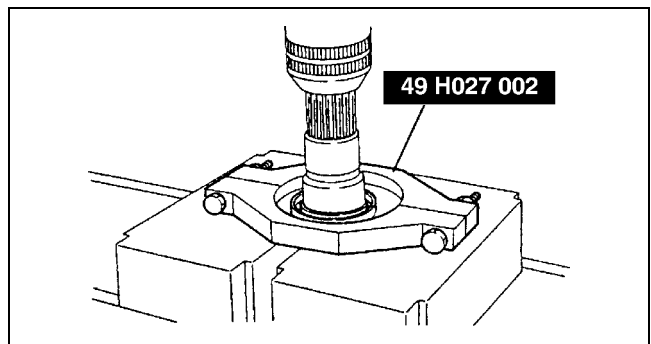

Y3E6316W015

03-13

Dust Seal (right) Assembly Note

1. Apply grease to a new dust seal lip.
2. Install the new right side dust seal using the **SSTs**.

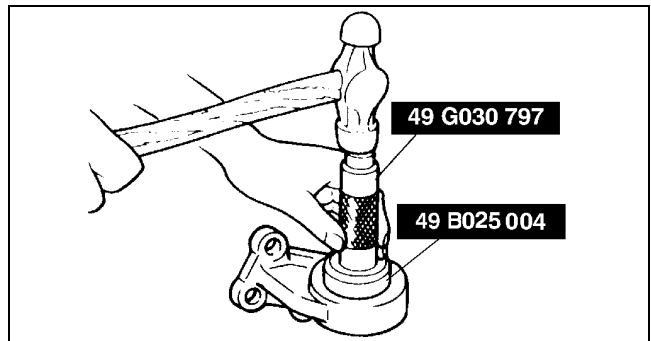

Y3E6316W016

Bearing Assembly Note

1. Install the new bearing using the **SSTs**.

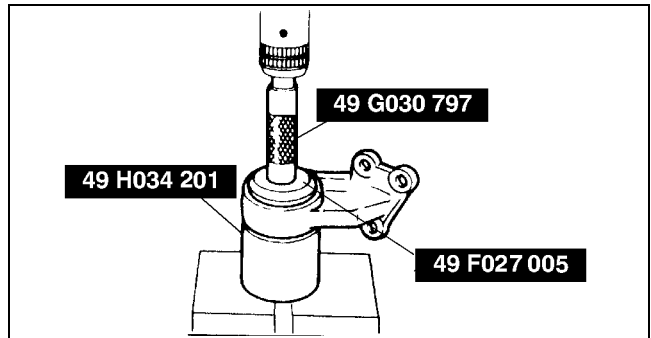

Y3E6316W017

Dust Seal (left) Assembly Note

1. Apply grease to a new dust seal lip.
2. Install the new left side dust seal using a steel plate and the **SSTs**.

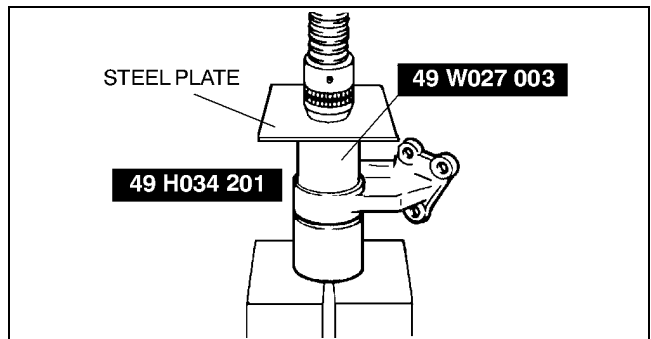

A3U0313W003

DRIVE SHAFT

Joint Shaft Assembly Note

1. Assemble the joint shaft using a press and the **SSTs**

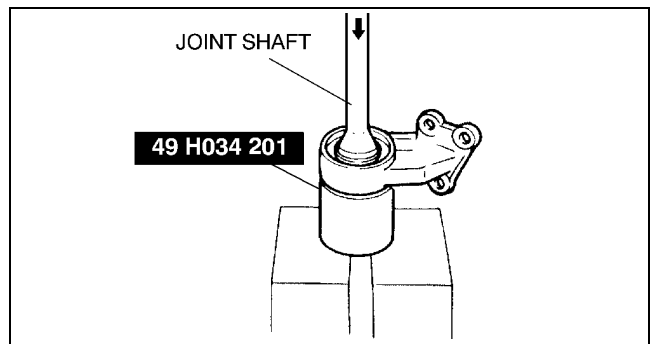

Y3E6316W019

DRIVE SHAFT PRE-INSPECTION

1. Inspect the dust boot on the drive shaft for cracks, damage, leaking grease, and looseness in the boot band.
2. Inspect the drive shaft for bends, cracks, and wear in the joint or splines.
 - Repair or replace the drive shaft or boot/band as necessary.

A3U031325500W02

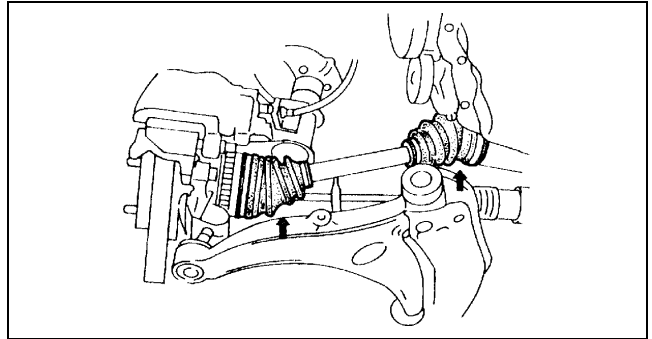

X3U313WAH

DRIVE SHAFT

DRIVE SHAFT REMOVAL/INSTALLATION

A3U03132550W03

Caution

- Performing the following procedures without first removing the ABS wheel-speed sensor may possibly cause an open circuit in the harness if it is pulled by mistake. Before performing the following procedures, remove the ABS wheel-speed sensor (axle side) and fix it to an appropriate place where the sensor will not be pulled by mistake while servicing the vehicle.

1. Drain the transaxle oil.
2. Remove the splash shield.
3. Remove in the order indicated in the table.
4. Install in the reverse order of removal.

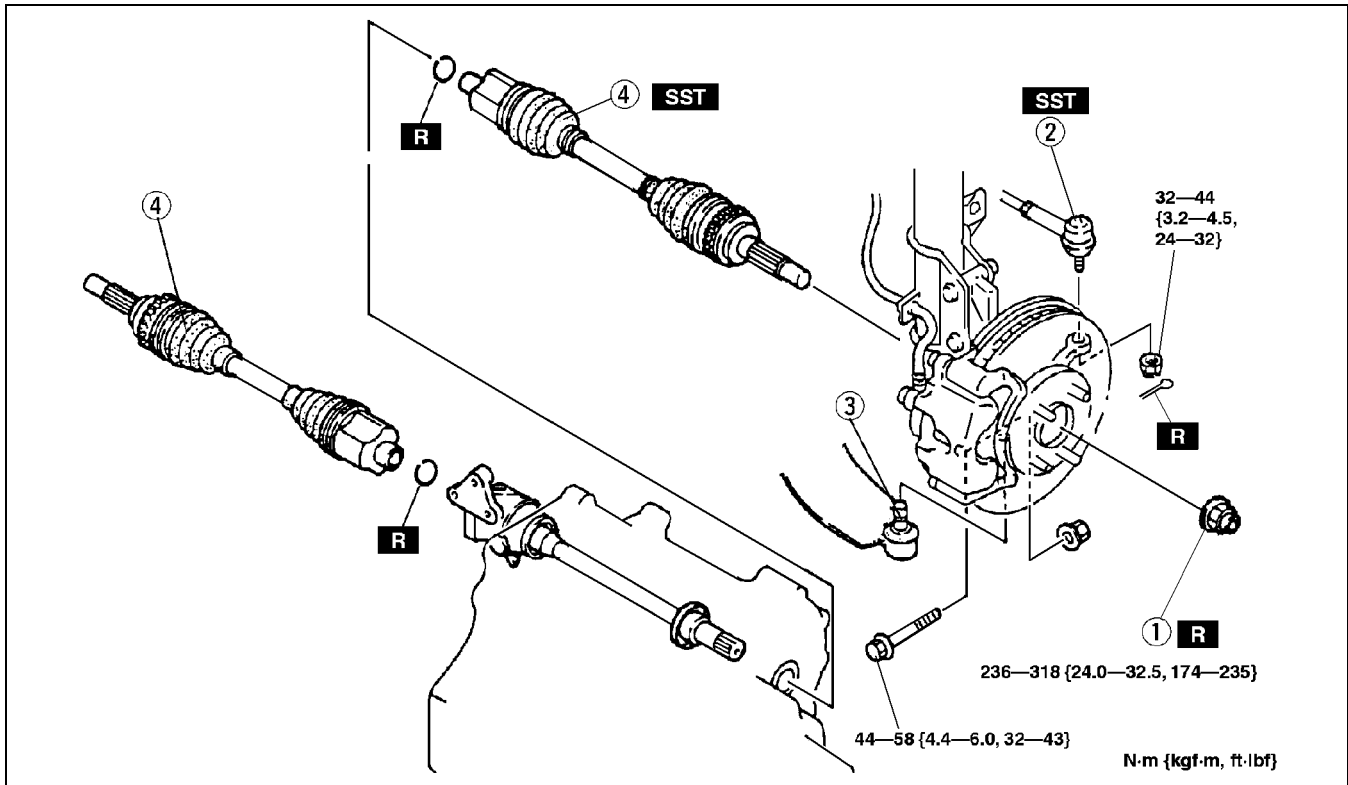

A3U0313W001

1	Locknut
2	Tie-rod end
3	Lower arm ball joint

4	Drive shaft (See 03-13-9 Drive Shaft Removal Note) (See 03-13-11 Drive Shaft Installation Note)
---	---

Drive Shaft Removal Note

1. Remove the clinch bolt and nut.
2. Wrap a rag around the ball joint dust boot.
3. Pry the lower arm out of the knuckle.
4. Install a spare nut onto the drive shaft so that the nut is flush with the end of the drive shaft.
5. Tap the nut with a copper hammer to loosen the drive shaft from the front wheel hub.

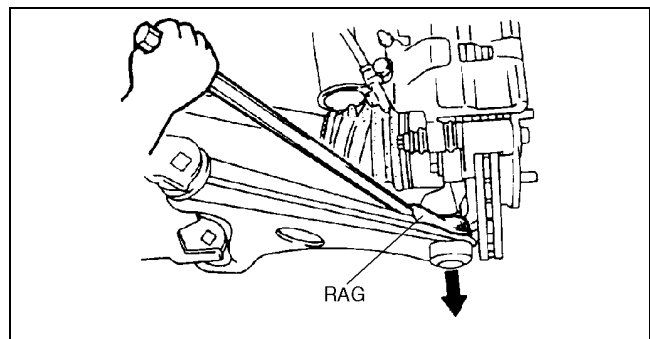

Z3U0312W003

03-13

DRIVE SHAFT

6. Separate the drive shaft from the wheel hub.

Caution

- The sharp edges of the drive shaft can slice or puncture the oil seal. Be careful when removing the drive shaft from the transaxle.

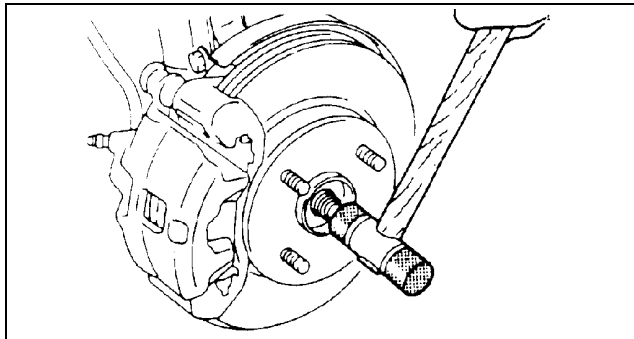

Y3E6316W020

7. Separate the left side drive shaft from the transaxle by prying with a bar inserted between the outer ring and the transaxle, as shown in the figure.

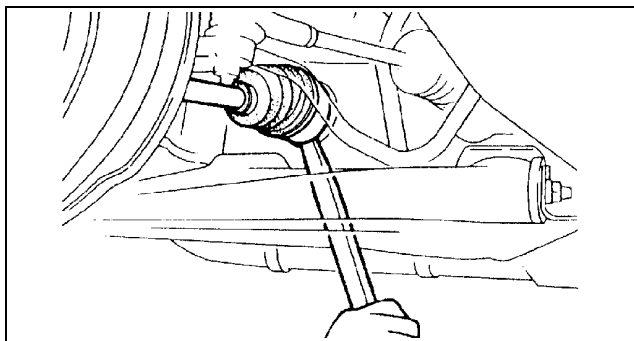

Y3E6316W021

8. Separate the right side drive shaft from the joint shaft by hammering on a bar inserted between them.

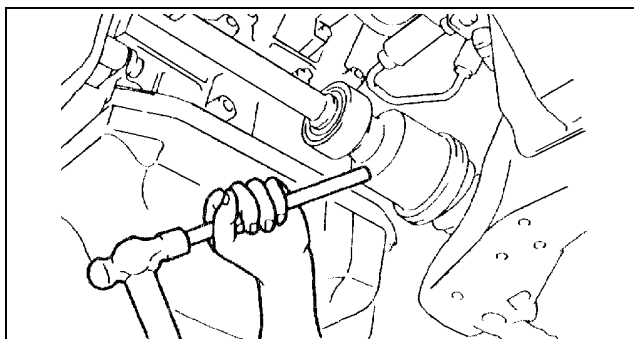

Y3E6316W007

9. Install the **SST** into the transaxle to hold the side gears after drive shaft is removed.

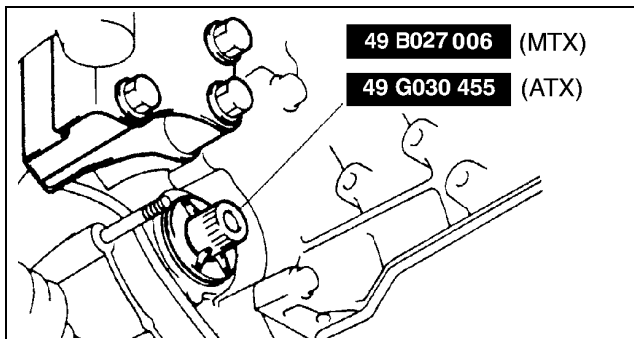

Y3E6316W009

DRIVE SHAFT

Drive Shaft Installation Note

(Left side)

1. Install a new clip onto the drive shaft with the opening facing upward. Ensure that the diameter of the clip does not exceed the specification on installation.
2. After installation, measure the outer diameter.
 - If it exceeds the specification, repeat Steps 1—2 using a new clip.

Outer diameter specification

mm {in}

Engine	Outer diameter
ZM (MTX)	27.2 {1.03}
ZM (ATX)	29.2 {1.15}
FS (MTX)	30.5 {1.20}
FS (ATX)	29.2 {1.15}

Caution

- The sharp edges of the drive shaft can slice or puncture the oil seal. Be careful when installing the drive shaft to the transaxle.
- The oil seals are damaged easily if this procedure is not done correctly.

3. Insert the drive shaft into the wheel hub.
4. Apply ATF to the oil seal lip.

5. Push the drive shaft into the transaxle.
6. After installation, pull the transaxle side outer ring forward to confirm that the drive shaft is securely held by the clip.

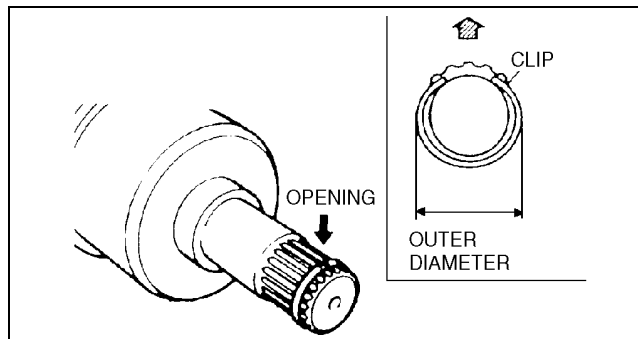

Z3U0312W004

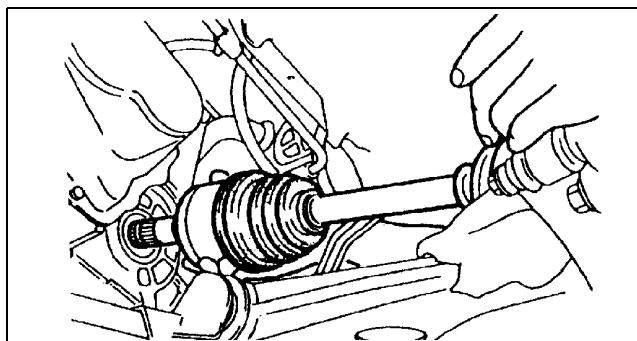

Y3E6316W023

(Right side)

1. Install the joint shaft with the end-gap of a new clip facing upward.
2. Install the drive shaft into the wheel hub.
3. Push the drive shaft into the joint shaft.
4. After installation, pull the transaxle side outer ring forward to confirm that the drive shaft is securely held by the clip.

DRIVE SHAFT

DRIVE SHAFT (ZM, FS ATX, FS MTX RIGHT SIDE) DISASSEMBLY/ASSEMBLY

A3U031325500W04

1. Disassemble in the order indicated in the table.
2. Assemble in the reverse order of disassembly.

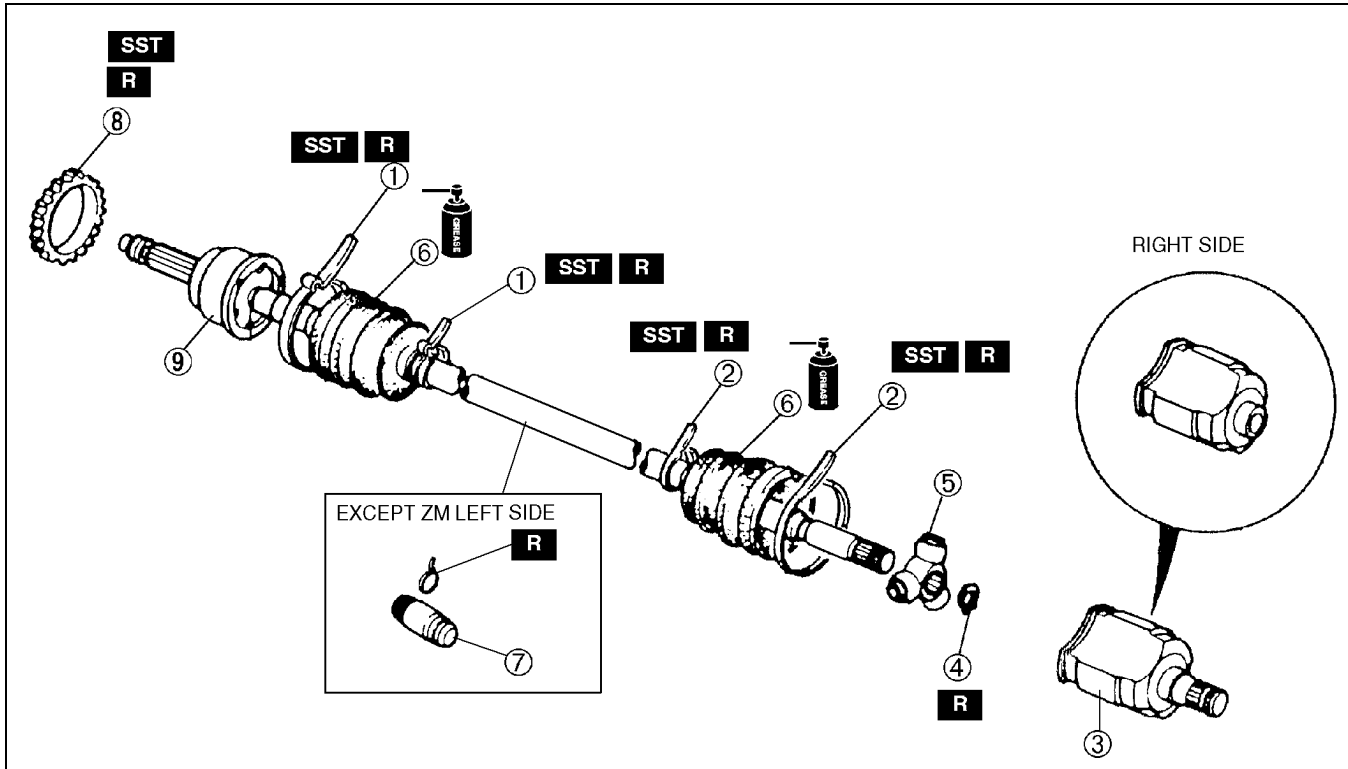

A3U0313W004

1	Boot band (wheel side) (See 03-13-12 Boot Band (Wheel Side) Disassembly Note) (See 03-13-16 Boot Band (Wheel Side) Assembly Note)
2	Boot band (transaxle side) (See 03-13-13 Boot Band (Transaxle Side) Disassembly Note) (See 03-13-16 Boot Band (Transaxle Side) Assembly Note)
3	Outer ring (See 03-13-13 Outer Ring Disassembly Note) (See 03-13-15 Outer Ring Assembly Note)
4	Snap ring

5	Tripod joint (See 03-13-13 Tripod Joint Disassembly Note) (See 03-13-15 Tripod Joint Assembly Note)
6	Boot (See 03-13-13 Boot Disassembly Note) (See 03-13-14 Boot Assembly Note)
7	Dynamic Damper (See 03-13-14 Dynamic Damper Assembly Note)
8	ABS sensor rotor (with ABS) (See 03-13-14 ABS Sensor Rotor (With ABS) Disassembly Note) (See 03-13-14 ABS Sensor Rotor (With ABS) Assembly Note)
9	Shaft and ball joint component

Boot Band (Wheel Side) Disassembly Note

Note

- Thoot band need not to be replaced if removed.

1. Remove the boot clamp with end clamp pliers as shown and discard the clamp.

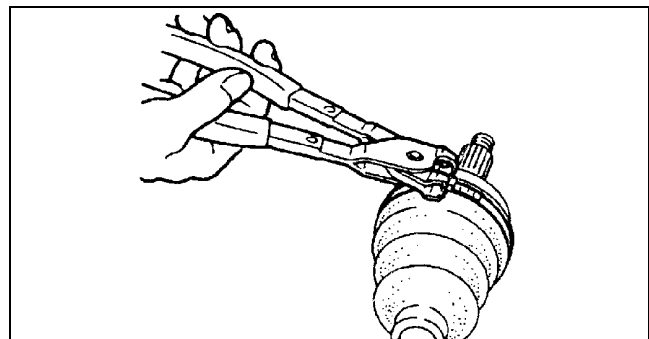

Y3E6316W025

DRIVE SHAFT

Boot Band (Transaxle Side) Disassembly Note

1. Pry up the locking clips using a screwdriver.
2. Pull back the end of the band.

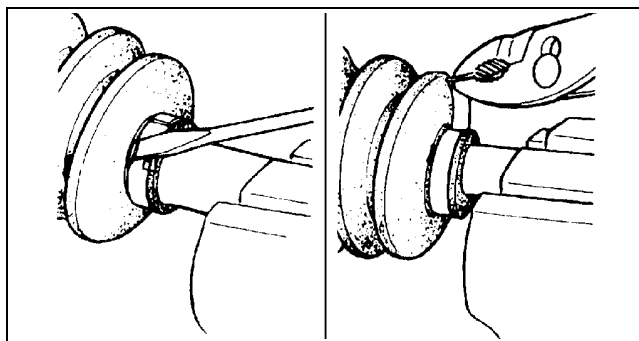

Y3E6316W031

03-13

Outer Ring Disassembly Note

1. Mark the outer ring and the shaft for proper assembly.
2. Remove the outer ring.

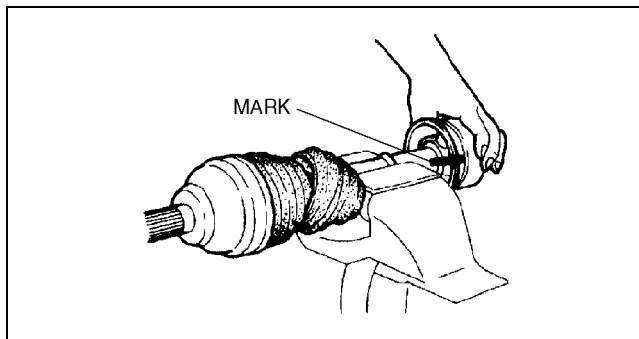

Z3U0313W002

Tripod Joint Disassembly Note

1. Mark the shaft and tripod joint for proper assembly.
2. Remove the snap ring using snap-ring pliers.
3. Remove the tripod joint from the shaft.

Caution

- Do not use a hammer to remove the joint shaft.

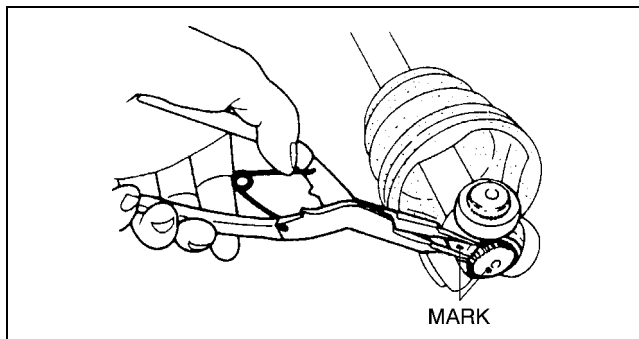

YDE6316W002

Boot Disassembly Note

Note

- The wheel side boot does not need to be removed unless replacing the boot or the ball joint and shaft component.
- Do not strip the tape until the boot is assembled.

1. Wrap the shaft splines with tape.
2. Remove the boot.

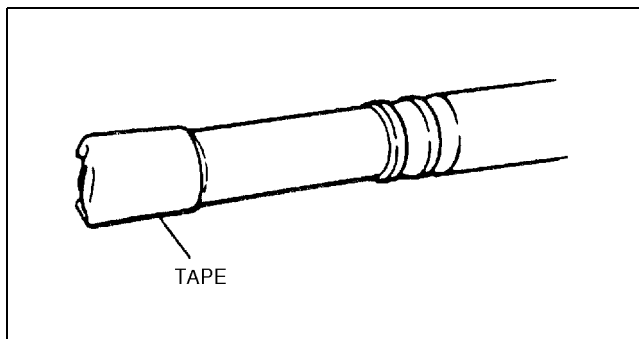

Z3U0313W003

DRIVE SHAFT

ABS Sensor Rotor (With ABS) Disassembly Note

Caution

- Do not remove the sensor rotor unless it is necessary.
- Do not reuse the sensor rotor if removed.

1. Tap the ABS sensor rotor off the drive shaft using a chisel.

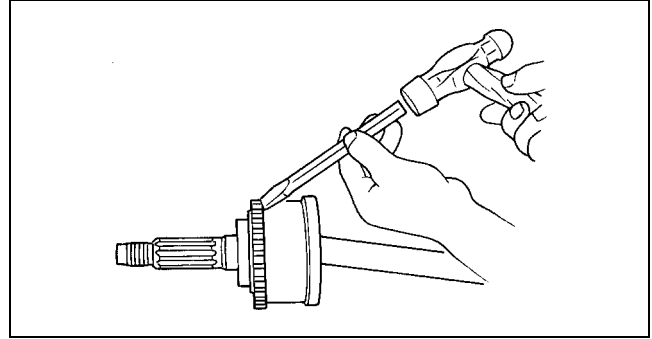

ZLU0313W105

ABS Sensor Rotor (With ABS) Assembly Note

1. Set a new ABS sensor rotor on the drive shaft and press it on using the SSTs.

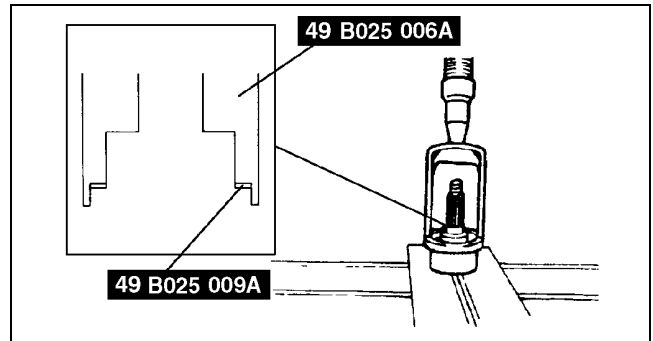

Z3U0313W004

Dynamic Damper Assembly Note

1. Install the dynamic damper as shown in the figure.

Standard length

292—298 mm {11.5—11.7 in}

2. Install the new boot band onto the dynamic damper.

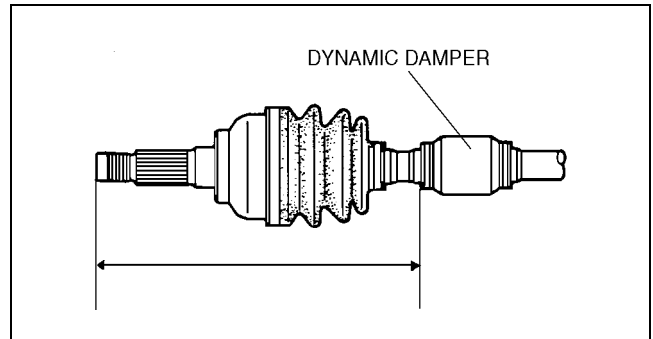

ZLU0313W141

Boot Assembly Note

1. Fill the boot (wheel side) with the specified grease .

Caution

- Do not touch grease with your hand. Apply it from the tube to prevent foreign matter from entering the boot.

Note

- The wheel side and transaxle side boots are different.
- Use the specified grease supplied in the boot kit.

Grease amount

ZM: 60—80 g {2.12—2.82 oz}

FS: 75—95 g {2.65—3.35 oz}

DRIVE SHAFT

2. Install the boot with the splines of the shaft still wrapped in tape from disassembly.
3. Remove the tape.

Tripod Joint Assembly Note

1. Align the marks and install the tripod joint using a bar and a hammer.

Caution

- Do not damage the roller.

2. Install the new snap ring using a snap-ring pliers.

Caution

- Install the snap ring in the shaft groove securely.

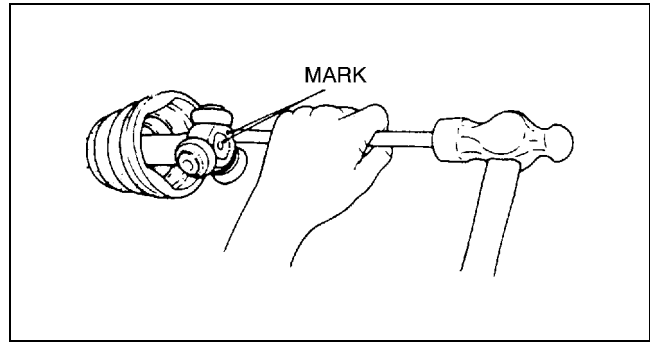

YDE6316W006

03-13

Outer Ring Assembly Note

1. Fill the outer ring and boot (transaxle side) with the specified grease from a tube, not by hand.

Caution

- Do not touch grease with your hand. Apply it from the tube to prevent foreign matter from entering the boot.

Note

- Use the specified grease supplied in the boot kit.

Grease amount

115—135 g {4.06—4.76 oz}

2. Install the outer ring.
3. Set the drive shaft to the standard length.

Standard length

mm {in}

Engine	Left side	Right side
ZM (MTX)	642.6—652.6 {25.30—25.69}	607.9—617.9 {23.94—24.32}
ZM (ATX)	626.7—636.7 {24.68—25.06}	
FS (MTX)	—	604.6—614.6 {23.81—24.19}
FS (ATX)	627.9—637.9 {24.73—25.11}	608.9—618.9 {23.98—24.36}

4. Release any trapped air from the boots by carefully lifting up the small end of each boot with a cloth wrapped screwdriver.

Caution

- Be careful not to allow the grease to leak.
- Do not damage the boot.

5. Verify that the drive shaft length is within the specification.

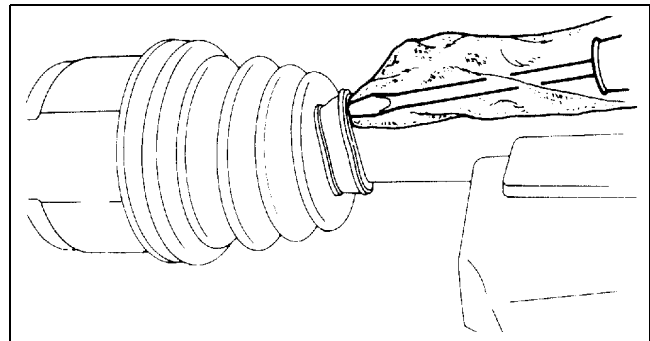

Y3E6316W033

DRIVE SHAFT

Boot Band (Transaxle Side) Assembly Note

1. Fold the band back and use pliers to pull it tight.

Note

- Always use new bands.
- The band should be folded in the direction opposite to the forward revolving direction of the drive shaft.

2. Lock the end of the band by bending the locking clips.

Caution

- Verify that the boot band is installed in the boot groove securely.

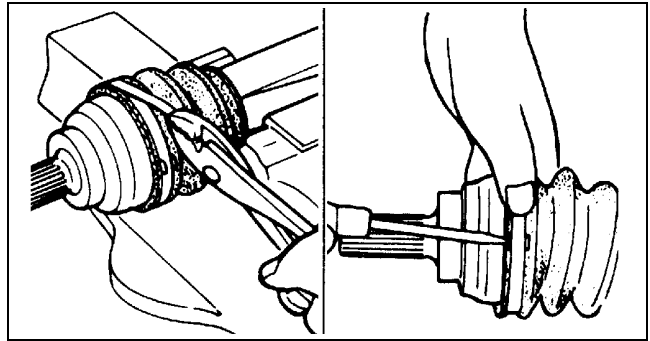

Y3E6316W035

Boot Band (Wheel Side) Assembly Note

1. Adjust clearance A by turning the adjusting bolt of the SST.

Clearance A

2.9 mm {0.11 in}

2. Crimp the wheel side small boot band using the SST. Verify that clearance B is within the specification.
 - If clearance B is more than the specification, reduce clearance A of the SST and crimp the boot again.
 - If clearance B is less than the specification, replace the boot band, increase clearance A of the SST, and crimp the new boot.

Clearance B

2.4—2.8 mm {0.095—0.110 in}

3. Verify that the boot band does not protrude from the boot band installation area.
 - If it does, replace the boot band and repeat from Step 1.
4. Fill the boot with the repair kit grease.
5. Adjust clearance A by turning the adjusting bolt of the SST.

Clearance A

3.2 mm {0.13 in}

6. Crimp the wheel side big boot band using the SST.
7. Verify that clearance B is within the specification.
 - If clearance B is more than the specification, reduce clearance A of the SST and crimp the boot again.
 - If clearance B is less than the specification, replace the boot band, increase clearance A of the SST and crimp the new boot.

Clearance B

2.4—2.8 mm {0.095—0.110 in}

8. Verify that the boot band does not protrude from the boot band installation area.
 - If it does, replace the boot band and repeat from Steps 5.

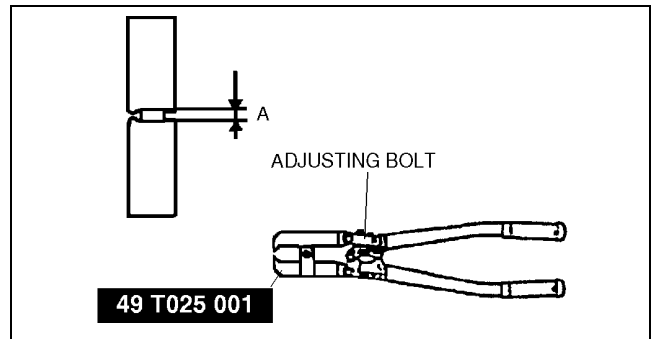

Z3U0313W009

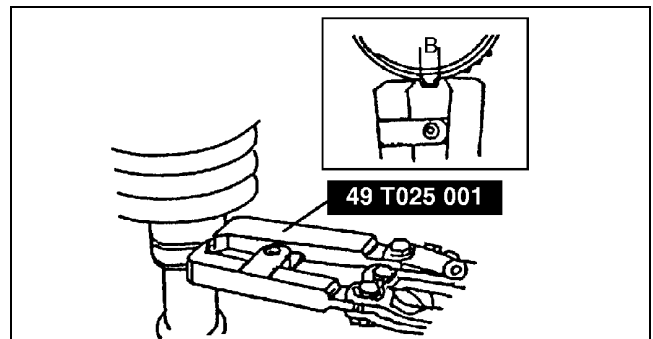

Y3E6316W028

DRIVE SHAFT

DRIVE SHAFT (FS MTX LEFT SIDE) DISASSEMBLY/ASSEMBLY

A3U03132550W05

1. Disassemble in the order indicated in the table.
2. Assemble in the reverse order of disassembly.

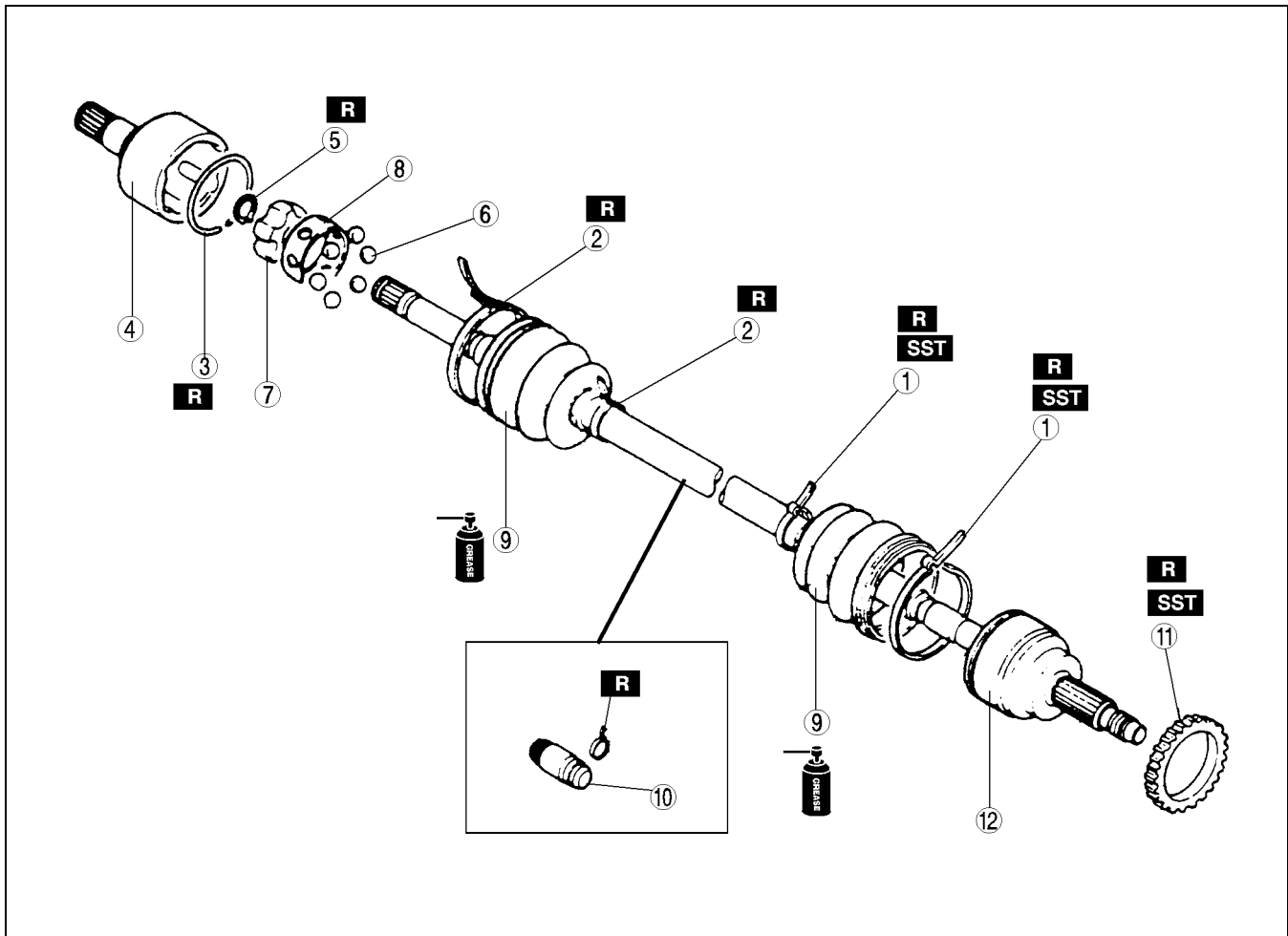

03-13

A3U0313W005

1	Boot band (wheel side) (See 03-13-12 DRIVE SHAFT (ZM, FS ATX, FS MTX RIGHT SIDE) DISASSEMBLY/ASSEMBLY)
2	Boot band (transaxle side) (See 03-13-12 DRIVE SHAFT (ZM, FS ATX, FS MTX RIGHT SIDE) DISASSEMBLY/ASSEMBLY)
3	Clip (See 03-13-18 Outer Ring Disassembly Note) (See 03-13-19 Outer Ring, Clip Assembly Note).
4	Outer ring (See 03-13-19 Outer Ring, Clip Assembly Note)
5	Snap ring (See 03-13-19 Cage, Inner Ring, Balls, Snap Ring Assembly Note)
6	Balls (See 03-13-18 Balls, Inner Ring, Cage Disassembly Note) (See 03-13-19 Cage, Inner Ring, Balls, Snap Ring Assembly Note)

7	Inner Ring (See 03-13-18 Balls, Inner Ring, Cage Disassembly Note) (See 03-13-19 Cage, Inner Ring, Balls, Snap Ring Assembly Note)
8	Cage (See 03-13-18 Balls, Inner Ring, Cage Disassembly Note) (See 03-13-19 Cage, Inner Ring, Balls, Snap Ring Assembly Note)
9	Boot (See 03-13-18 Boot Assembly Note)
10	Dynamic damper (See 03-13-18 Dynamic Damper Assembly Note)
11	ABS sensor rotor (See 03-13-12 DRIVE SHAFT (ZM, FS ATX, FS MTX RIGHT SIDE) DISASSEMBLY/ASSEMBLY)
12	Shaft and ball joint component

DRIVE SHAFT

Outer Ring Disassembly Note

1. Mark the drive shaft and outer ring for proper assembly.

Caution

- Mark with paint; do not use a punch.

2. Remove the clip.

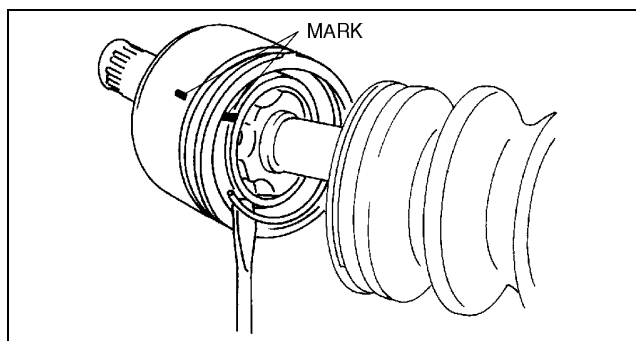

Z3U0313W005

Balls, Inner Ring, Cage Disassembly Note

1. Mark the inner ring and cage.

Caution

- Mark with paint; do not use a punch.

2. Remove the snap ring using snap-ring pliers.
3. Turn the cage approximately 30 degree and pull the cage and balls away from the inner ring.

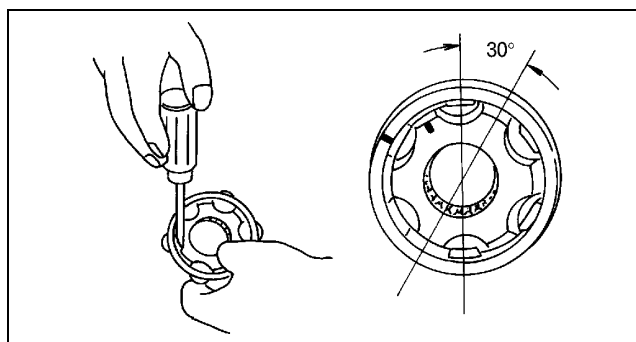

YYJ6316W007

Dynamic Damper Assembly Note

1. Install the dynamic damper as shown in the figure.

Standard length

292—298 mm {11.5—11.7 in}

2. Install the new boot band onto the dynamic damper.

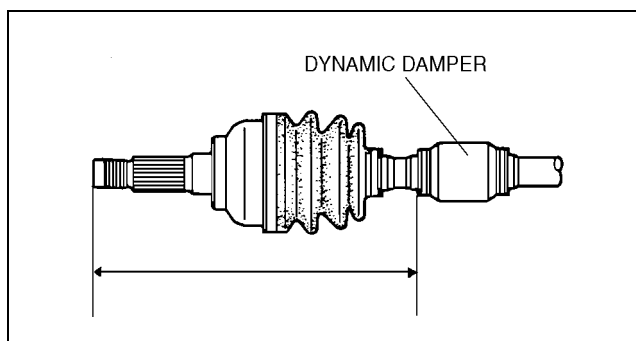

ZLU0313W141

Boot Assembly Note

1. Fill the boot (wheel side) with the specified grease from a tube, not by hand.

Caution

- Do not touch grease with your hand. Apply it from the tube to prevent foreign matter from entering the boot.

Note

- The wheel side and transaxle side boots are different.
- Use the specified grease supplied in the boot kit.

Grease amount

75—95 g {2.65—3.35 oz}

DRIVE SHAFT

2. With the splines of the shaft still wrapped in tape from disassembly, install the boot.
3. Remove the tape.

Cage, Inner Ring, Balls, Snap Ring Assembly Note

1. Align the marks and install the balls and cage to the inner ring in the direction shown in the figure.

Caution

- Install the cage with the offset facing the snap ring groove. If incorrectly installed, the drive shaft may become disengaged.

2. Install a new snap ring.

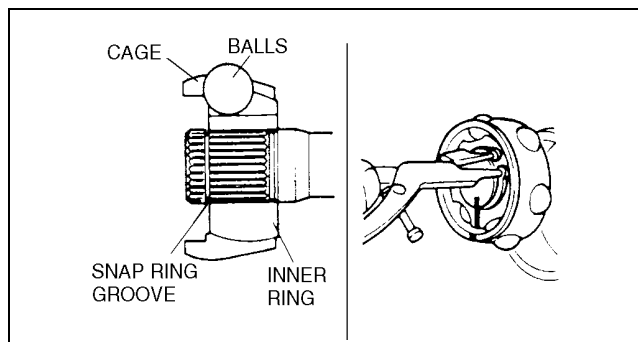

Z3U0313W006

03-13

Outer Ring, Clip Assembly Note

1. Fill the outer ring and boot (transaxle side) with the specified grease.

Caution

- Do not touch grease with your hand. Apply it from the tube to prevent foreign matter from entering the boot.

Note

- Use the specified grease supplied in the boot kit.

Grease amount

95—115 g {3.36—4.05 oz}

2. Align the marks, and install the outer ring on to the shaft.
3. Install a new clip.
4. Install the boot.
5. Set the drive shaft to the standard length.

Standard length

641.0—651.0 {25.24—25.62}

6. Release any trapped air from the boots by carefully lifting up the small end of each boot with a cloth wrapped screwdriver.

Caution

- Be careful not to allow the grease to leak.
- Do not damage the boot.

7. Verify that the drive shaft length is within the specification.

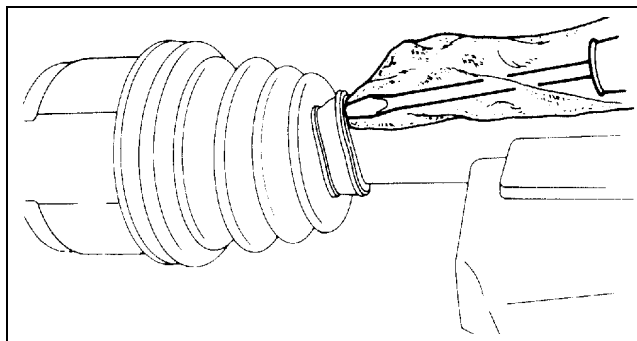

Y3E6316W033