

03-11 FRONT AXLE

FRONT AXLE LOCATION INDEX 03-11-1

WHEEL HUB, STEERING KNUCKLE

PRE-INSPECTION 03-11-1

 Wheel Bearing Play Inspection 03-11-1

WHEEL HUB BOLT REPLACEMENT .. 03-11-2

WHEEL HUB, STEERING KNUCKLE

REMOVAL/INSTALLATION 03-11-3

 Locknut Removal Note 03-11-4

 Wheel Hub Component

 Removal Note 03-11-4

Wheel Bearing Removal Note 03-11-4

Dust Cover Removal Note 03-11-5

Hub Bolt Removal Note 03-11-5

Hub Bolt Installation Note 03-11-5

Dust Cover Installation Note 03-11-6

Wheel Bearing Installation Note 03-11-6

Wheel Hub Component

 Installation Note 03-11-6

Oil Seal Installation Note 03-11-7

Locknut Installation Note 03-11-7

03-11

FRONT AXLE LOCATION INDEX

A3U031104000W01

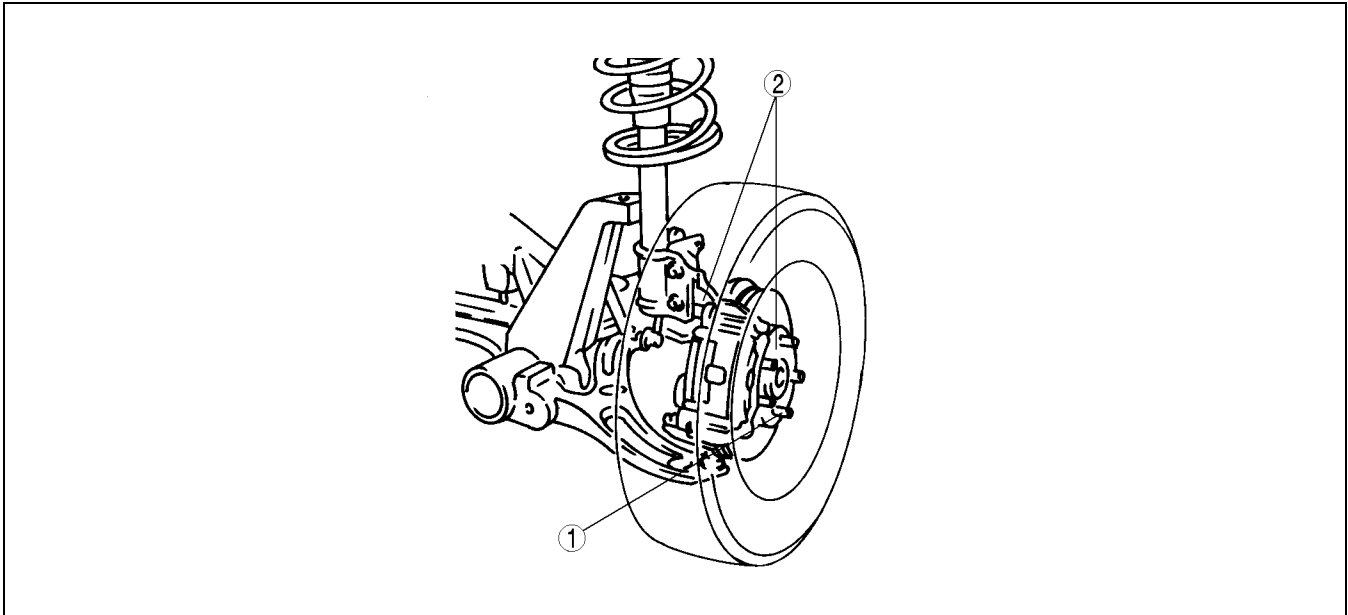

Z3U0311W001

1	Hub bolt (See 03-11-2 WHEEL HUB BOLT REPLACEMENT)
---	--

2	Wheel hub, steering knuckle (See 03-11-3 WHEEL HUB, STEERING KNUCKLE REMOVAL/INSTALLATION) (See 03-11-1 WHEEL HUB, STEERING KNUCKLE PRE-INSPECTION)
---	---

WHEEL HUB, STEERING KNUCKLE PRE-INSPECTION

A3U031104000W02

Wheel Bearing Play Inspection

1. Position a dial indicator against the wheel hub.
2. Push and pull the wheel hub by hand in the axial direction and measure the wheel bearing play.
 - If the bearing play exceeds the specification, replace the wheel bearing as necessary and tighten the locknut to the specified torque and retest.

Maximum wheel bearing play
0.05 mm {0.002 in}

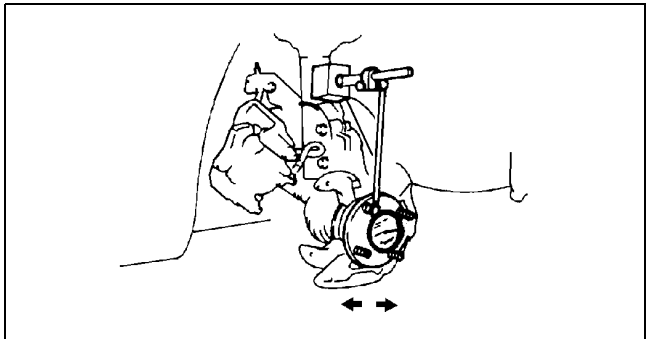

A3U0311W010

FRONT AXLE

WHEEL HUB BOLT REPLACEMENT

A3U031104000W03

1. Remove the hub bolt using the **SSTs**.

Note

- If the dust cover interferes with the wheel hub bolt and the wheel hub bolt cannot be removed, tap the part shown in the figure with a chisel lightly and bend the processing point back to the steering knuckle side.

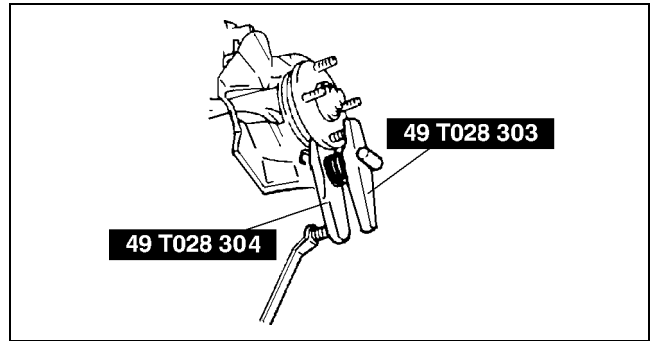

A3U0311W007

2. Install the hub bolt into the wheel hub and install a washer and hub nut on the hub bolt.

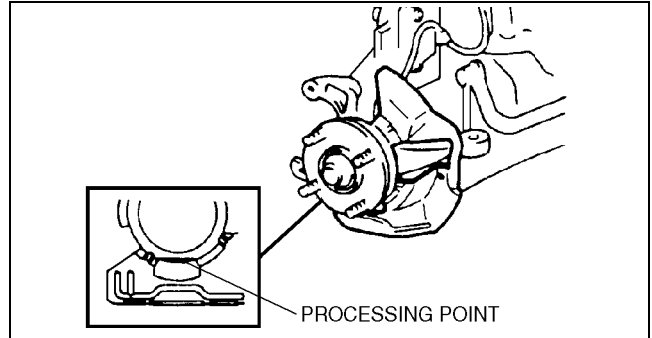

A3U0311W002

3. Tighten the hub nut while holding the wheel hub using a brass bar.

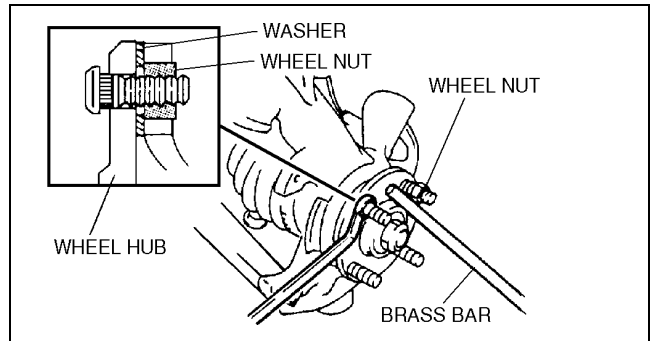

A3U0311W003

FRONT AXLE

WHEEL HUB, STEERING KNUCKLE REMOVAL/INSTALLATION

A3U03110400W04

Caution

- Performing the following procedures without first removing the ABS wheel-speed sensor may possibly cause an open circuit in the harness if it is pulled by mistake. Before performing the following procedures, remove the ABS wheel-speed sensor (axle side) and fix it to an appropriate place where the sensor will not be pulled by mistake while servicing the vehicle.

- Remove in the order indicated in the table.
- Install in the reverse order of removal.
- After installation, inspect the front wheel alignment. (See 02-11-1 FRONT WHEEL ALIGNMENT.)

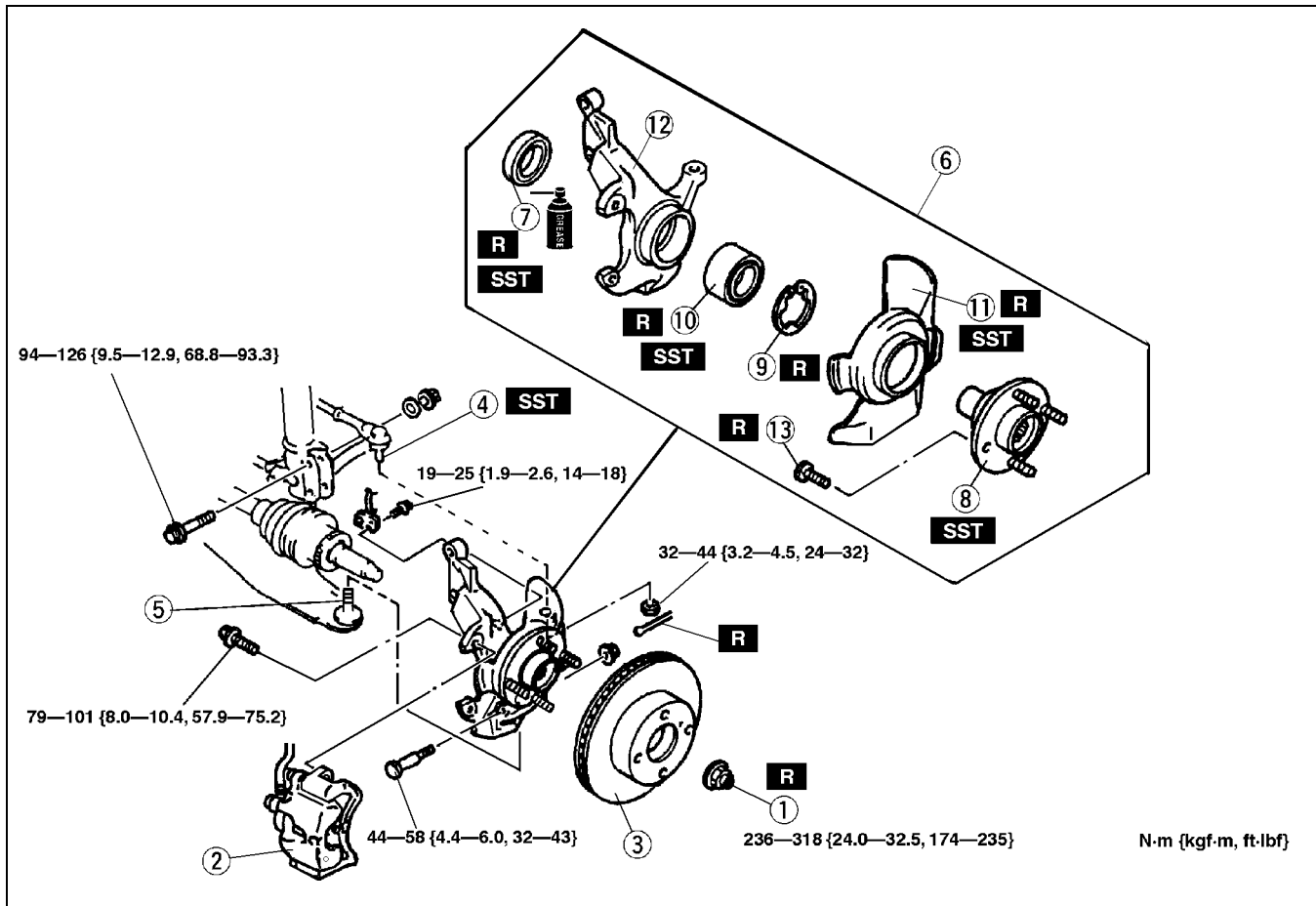

03-11

A3U0311W001

1	Locknut (See 03-11-4 Locknut Removal Note) (See 03-11-7 Locknut Installation Note)
2	Brake caliper component
3	Disc plate
4	Tie-rod end (See 06-12-10 Tie-rod End Ball Joint Removal Note)
5	Lower arm ball joint
6	Wheel hub, steering knuckle, dust cover
7	Oil seal (See 03-11-7 Oil Seal Installation Note)
8	Wheel hub component (See 03-11-4 Wheel Hub Component Removal Note) (See 03-11-6 Wheel Hub Component Installation Note)

9	Retaining ring
10	Wheel bearing (See 03-11-4 Wheel Bearing Removal Note) (See 03-11-6 Wheel Bearing Installation Note)
11	Dust cover (See 03-11-5 Dust Cover Removal Note) (See 03-11-6 Dust Cover Installation Note)
12	Steering knuckle
13	Hub bolt (See 03-11-5 Hub Bolt Removal Note) (See 03-11-5 Hub Bolt Installation Note)

FRONT AXLE

Locknut Removal Note

1. Knock the crimped portion of the locknut outward using a small chisel and a hammer.
2. Lock the hub by applying the brakes.
3. Remove the locknut.

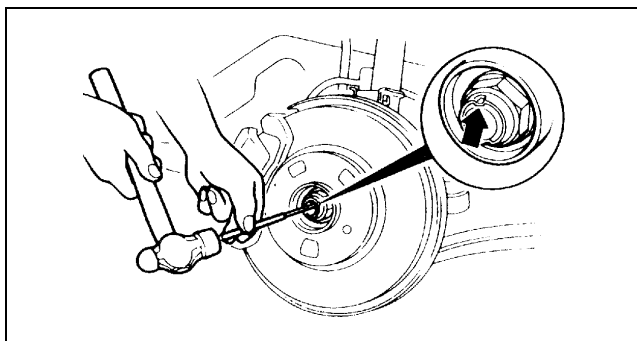

X3U311WA5

Wheel Hub Component Removal Note

1. Remove the wheel hub component using the SSTs.

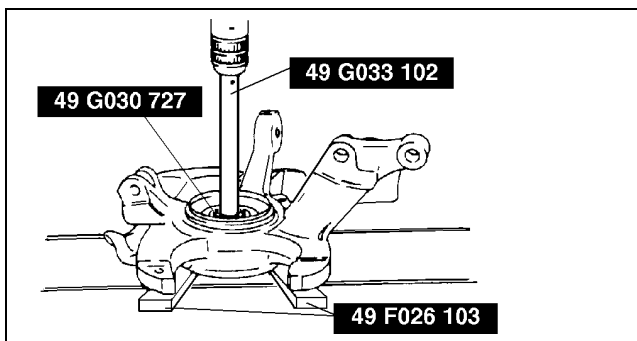

A3U0311W008

2. If the bearing inner race remains on the front wheel hub component, grind a section of the bearing inner race until **approx. 0.5 mm {0.020 in}** remains. Then remove it using a chisel.

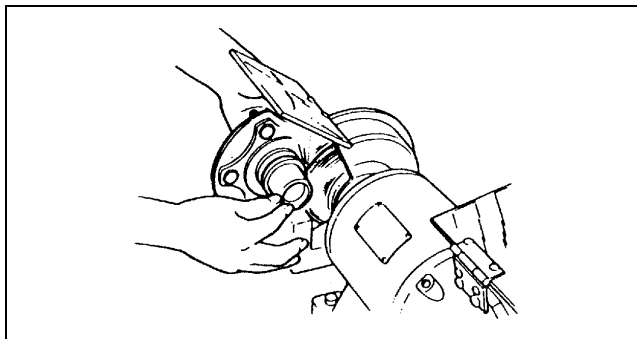

X3U311WA7

Wheel Bearing Removal Note

1. Remove the wheel bearing using the SSTs.

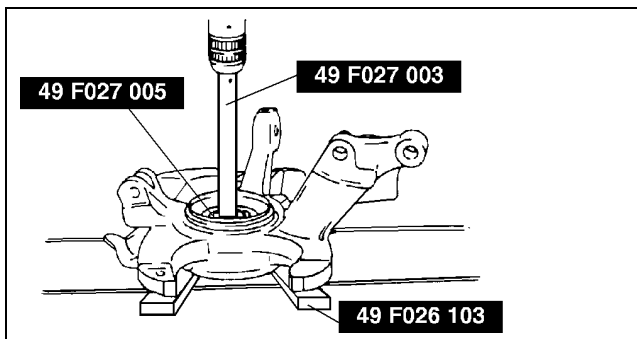

A3U0311W009

FRONT AXLE

Dust Cover Removal Note

Note

- The dust cover does not need to be removed unless it is being replaced.

1. Mark the dust cover and steering knuckle for proper installation.

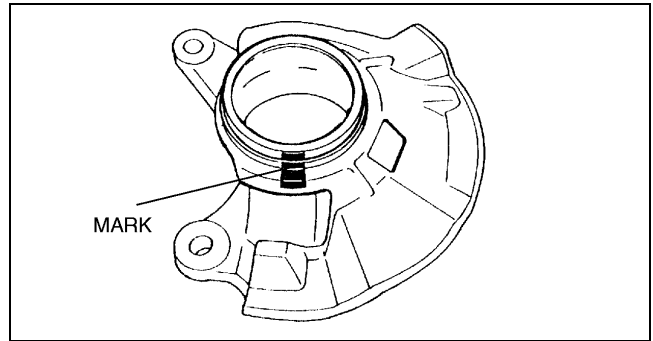

Y3U311WA1

03-11

2. Remove the dust cover using a chisel.

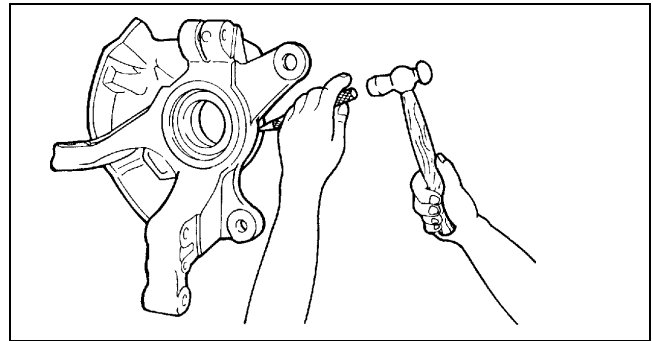

X3U311WAA

Hub Bolt Removal Note

Note

- The hub bolts do not need to be removed unless they are being replaced.

1. Remove the hub bolts using a press.

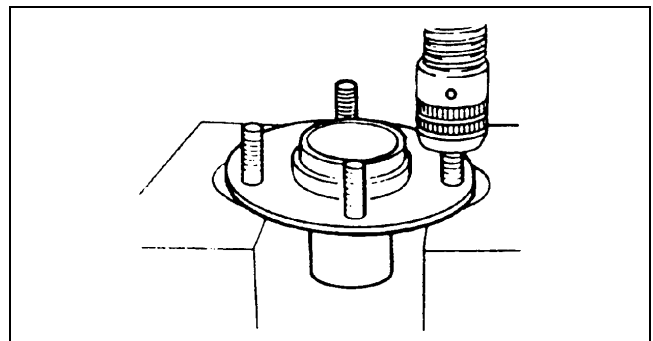

X3U311WAB

Hub Bolt Installation Note

1. Install the new hub bolts using a press.

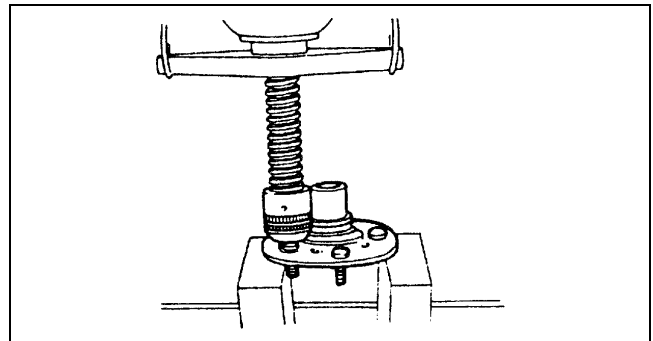

X3U311WAC

FRONT AXLE

Dust Cover Installation Note

1. Mark the new dust cover in the same way as the removed one.
2. Align the marks of the new dust cover and the knuckle.

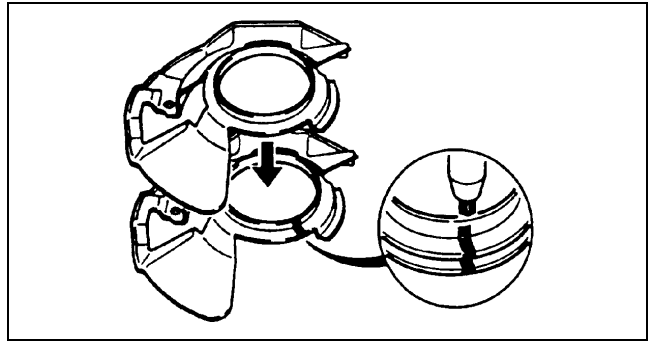

X3U311WAD

3. Install the new dust cover using the SSTs.

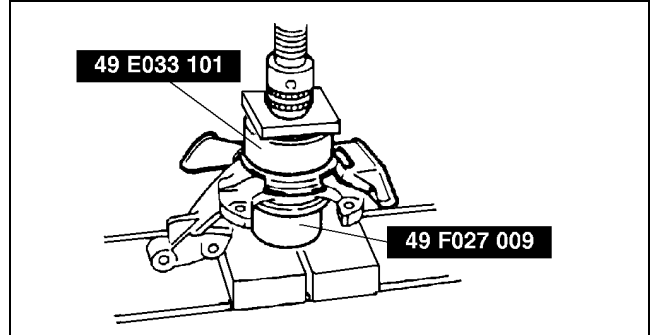

A3U0311W004

Wheel Bearing Installation Note

1. Install the new wheel bearing using the SSTs.

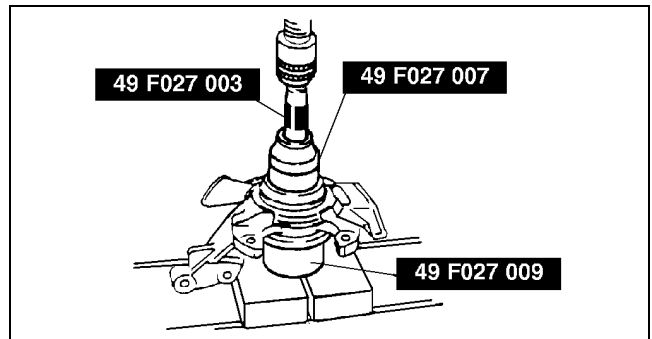

A3U0311W005

Wheel Hub Component Installation Note

1. Install the wheel hub component using the SST.

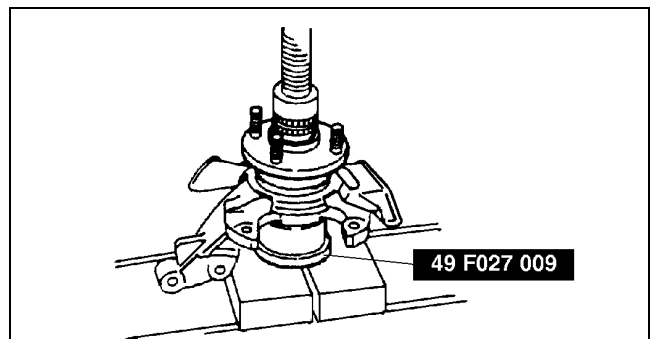

A3U0311W006

FRONT AXLE

Oil Seal Installation Note

1. Apply grease to the new oil seal lip.
2. Install the new oil seal flush with the knuckle using the **SST**.

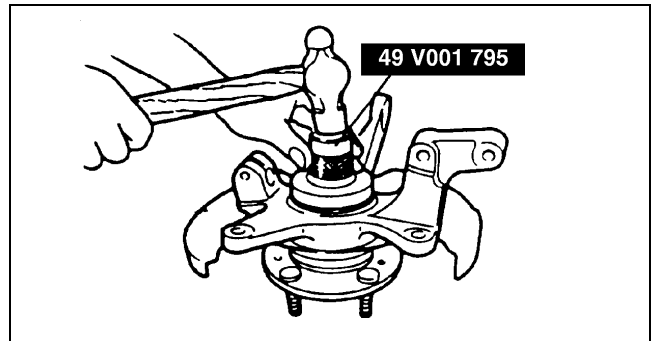

X3U31WAH

03-11

Locknut Installation Note

1. Install a new locknut and stake it as shown.

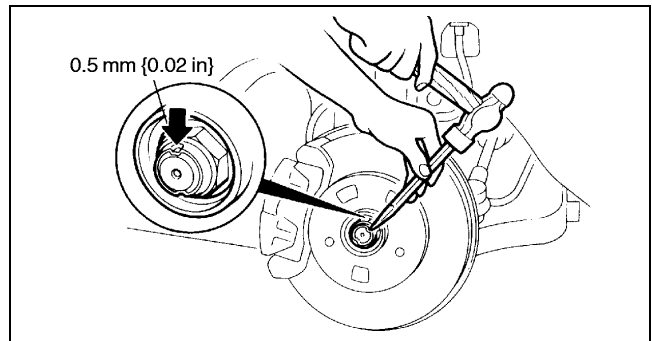

X3U31WAJ